

ADT-CNC4220

CNC Lathe Control System

User Manual

Programme

ADTECH 众为兴

Adtech (Shenzhen) CNC Technology Co., LTD

Address: F/5, 36th Building, MaJiaLong Industrial Park, Nanshan District,
Shenzhen City, China P.C: 518052

TEL:+86-755-26099116 FAX:+86-755-2672 2718

Website://www.adtechen.com E-mail: export@adtechen.com

System Introduction

CNC4220 is the universal machine tool numerical control system developed by our company. As the update product of economic numerical control system, CNC4220 features the following technical characteristics:

- Realize the high speed μm grade control with 32-bit CPU and hardware interpolation technology;
- LCD Chinese display, featuring friendly interface and convenient operation;
- Adjustable acceleration/deceleration, step drive or servo drive can be equipped;
- Variable electronic gear ration, featuring convenient application;
- High speed interface refreshing;
- Large storage space: 256MB, saving up to 9999 program files;
- User programmable I/O point control function;

Copyright

Adtech (Shenzhen) CNC Technology Co., Ltd. (Adtech hereafter) is in possession of the copyright of this manual. Without written permission, the imitation, copy, or translation by any organization or individual is prohibited. This manual assures no guarantee, position expression or implied other. If any direct or indirect information disclosure, loss of profits or cause termination is caused by any information in this manual or about the product, Adtech and the employees do not bear any responsibility. In addition, the products and the information mentioned in this manual are for reference only. The content is subject to changes without prior notice.

Copyright! All rights reserved!

Version

Item No.	Version No.	Modification date	Description
XT20061225	9.0	2010/2/23	9th

Remark: the meaning of the three figures in the version number follows:



Main library version No.

Secondary library version No.

Reserved

Remark:

1. Adtech has checked and reviewed this manual strictly; however, we won't guarantee that there is no mistake or omission in this manual.
2. Adtech is devoted to improving product function and service quality. The products, software and contents of the manual are subject to changes without prior notice.

Precautions

☞ **※Transport and storage**

- ☞ Do not stack the carton for more than six layers.
- ☞ Do not climb, stand on or put heavy objects on the carton.
- ☞ Do not drag or carry the product with the cables connected to the product.
- ☞ Do not collide with or scratch the panel and display; keep the carton away from moisture, insolation and drenching.

☞ **※Unpacking and Checking**

- ☞ When unpacking the product, make sure the product inside the package is what you bought.
- ☞ Check whether the product was damaged during the transport.
- ☞ Check with the packing list to see whether all items are in the carton and whether there is any damage to the product. If the model of the product is inconsistent with that in the order, there is any omitted item or the product is damaged during the transport process, please contact Adtech as soon as possible.

☞ **※Wiring**

- ☞ The wiring of the system must be carried out by professionals.
- ☞ The product must be reliable grounded, with grounding resistance not less than 4 ohms. It is not allow that a neutral line be used as the grounding wire.
- ☞ To avoid failure or unexpected consequences, the wiring of the system must be carried out properly and reliably.
- ☞ The surge-absorption diode must be connected to the product to the extent that the designated direction is followed. Otherwise, the plug may be damaged. Disconnect power supply of the product before the casing is opened.

☞ **※Repair**

- ☞ The user must cut off the power before the system is repaired or any part is replaced.
- ☞ In case of short circuit or overloading, the user should check what the problem is and only after the problem is solved can the system be started again. Never frequently turn on and off the power. There should be at least one-minute interval between the power-on and power-off states.

Contents

1. Foundation of programming	7
1.1 Overview	7
1.2 Definition of coordinate axis	8
1.2 DEFINITION OF COORDINATE AXIS	- 7 -
1.3 COORDINATES OF THE MACHINE TOOL AND MECHANICAL ORIGIN.....	- 8 -
1.4 WORKPIECE COORDINATES AND PROGRAM ORIGIN	- 8 -
1.5 PROGRAMMING WITH ABSOLUTE AND RELATIVE COORDINATES.....	- 9 -
1.6 CONVERSION BETWEEN BRITISH SYSTEM AND METRIC SYSTEM	- 10 -
1.7 DEFINITION OF PROGRAM	- 11 -
1.8 COMPOSITION OF PROGRAM.....	- 12 -
1.9 MAIN PROGRAM AND SUBROUTINE.....	- 14 -
2.1 AUXILIARY FUNCTIONS (M INSTRUCTION)	- 14 -
2.1.1 Subroutine call (M98)	- 16 -
2.1.2 Return from subroutine and to main program (M99).....	- 16 -
2.1.3 Spindle control (M03, M04 and M05)	- 18 -
2.1.4 Coolant control (M08 and M09)	- 19 -
2.1.5 Tailstock control (M10 and M11).....	- 19 -
2.1.6 Chuck control (M12 and M13)	- 19 -
2.1.7 Lubricant control (M32 and M33)	- 19 -
2.1.8 Program pause (M00)	- 20 -
2.1.9 Program end and return (M30).....	- 20 -
2.2 PROGRAMMABLE INPUT/OUTPUT INSTRUCTIONS	- 20 -
2.2.1 Programmable input instruction (M88).....	- 20 -
2.2.2 Programmable output instruction (M89).....	- 20 -
2.3 FUNCTIONS OF SPINDLE (S INSTRUCTION).....	- 21 -
2.3.1 Switch-controlled spindle speed	- 21 -
2.3.2 Analog voltage control for the spindle.....	- 21 -
2.3.3 Spindle magnification	- 22 -
2.3.4 Constant linear speed control (G96) and constant rotation speed control (G97) ..	- 22 -
2.3.5 Limit of spindle's max. speed.....	- 22 -
2.4 QUICK MOVE AND FEED (G98/G99, F INSTRUCTION).....	- 23 -
2.4.1 Quick move.....	- 23 -
2.4.2 F instruction for cutting feed	- 23 -
2.4.1. G98, G99.....	- 24 -
2.4.4 Manual feed.....	- 25 -

2.5 TOOL OFFSET (T INSTRUCTION)	- 26 -
3. G INSTRUCTION	- 28 -
3.1 OVERVIEW	- 28 -
3.1.1 Mode, non-mode and initial state	- 29 -
3.1.2 Definitions	- 29 -
3.2 INTERPOLATION.....	- 30 -
3.2.1 Quick move (G00)	- 30 -
3.2.2. Linear interpolation (G01)	- 31 -
3.2.3 Arc interpolation (G03 and G02)	- 32 -
3.2.4 Pause (G04)	- 35 -
3.2.5 Check of returning from reference point (G27)	- 35 -
3.2.6 Return to mechanical origin (G28)	- 36 -
3.2.7 Return from the reference point (G29)	- 38 -
3.2.8 Return to the 2nd reference point (G30)	- 39 -
3.3 THREAD CUTTING.....	- 39 -
3.3.1 Thread cutting (G32)	- 39 -
3.3.2 Axis Z's tapping cycle (G33)	- 42 -
3.4 SETTING WORKPIECE'S COORDINATES (G50)	- 43 -
3.5 FIXED CYCLE.....	- 45 -
3.5.1 Axial cutting cycle (G90)	- 45 -
3.5.2 Thread cutting cycle (G92)	- 47 -
3.5.3 Radial cutting cycle (G94)	- 51 -
3.5.4 Precautions on fixed cycle instruction	- 53 -
3.6 MULTI-CYCLE INSTRUCTIONS.....	- 53 -
3.6.1 Axial rough cutting cycle (G71)	- 54 -
3.6.2 Radial rough cutting cycle (G72)	- 58 -
3.6.3 Enclosed rough cutting cycle (G73)	- 63 -
3.6.4 Fine machining cycle (G70)	- 68 -
3.6.5 Axial slot-cutting multi-cycle (G74)	- 69 -
3.6.6 Radial slot-cutting multi-cycle (G75)	- 72 -
1. CNC PROCESS	- 75 -

Foundation of programming

1.1 Overview

Consisting of CNC (computer numerical controller), servo motor (or stepper motor) driver, machine tool (including spindle box, feeding transmission mechanism, work station, tool apron and electric cabinet) and other parts, a CNC machine tool works in such a way that, after the edited program of the part is processed by CNC, motion instruction and control instruction will be sent out, the former of which will be used to enable the feeding movement of the machine tool through the motor-operated driver, and the later of which will perform such controls as on/off state of spindle, tool selection, cooling and lubricating, and the part is machined through the relative movement of the tool and workpiece.

The CNC programming is a process in which the outer dimensions, machining procedure, process parameters, tool parameters and other information are compiled as the machining program of the part in accordance with the program instructions exclusively used by CNC. CNC machining is another process in which CNC controls the machine tool to machine the part on the basis of the requirements of the machining program. The working principle of CNC machining tool and process flow of CNC machining are shown in the figure below

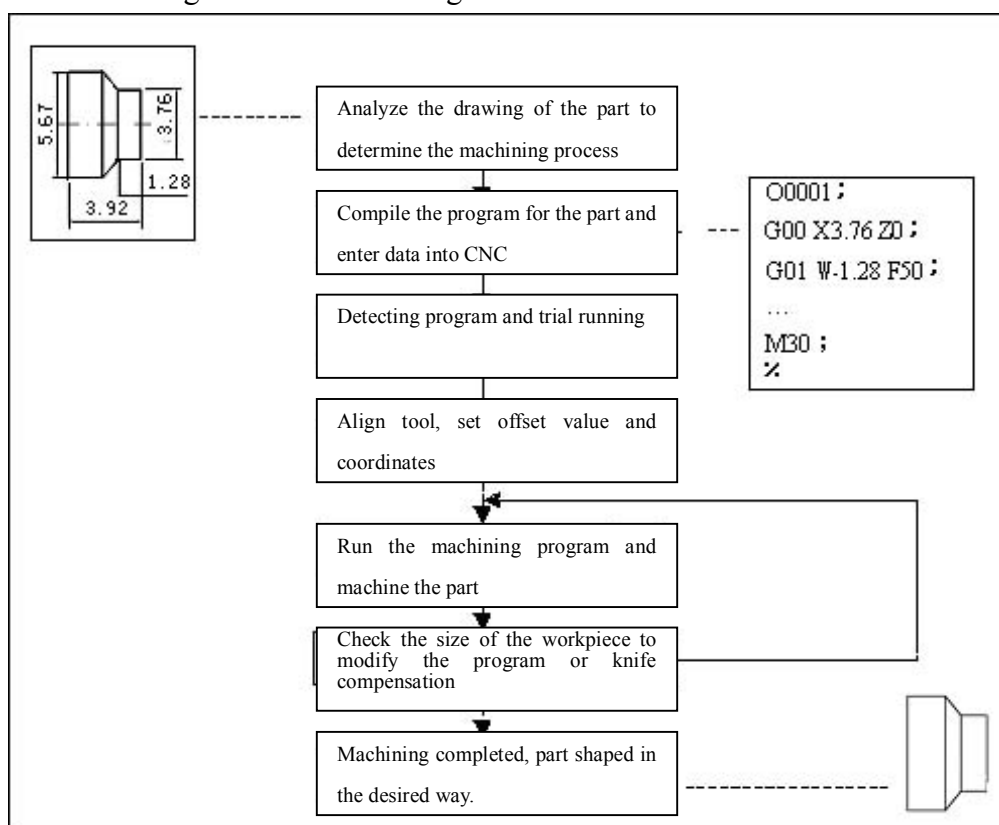

Figure 1 Process flow of CNC machining

1.2 Definition of coordinate axis

The abridged general view of the CNC machine tool is can be seen in Figure 1-1-1.

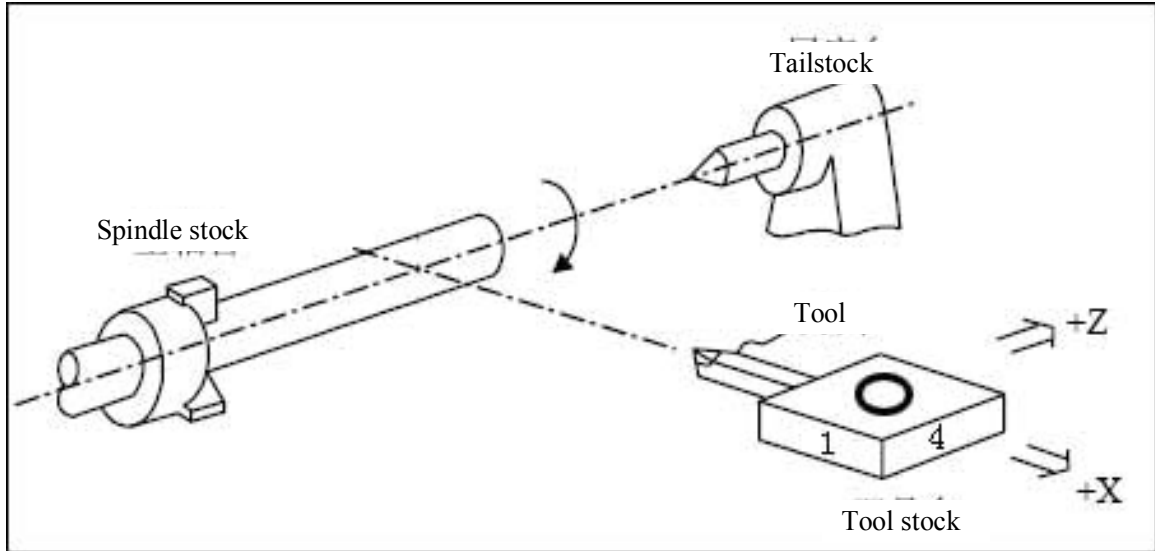

Fig.1-1-1

This system employs the rectangular coordinates, whose axis X is vertical to the axial line of the spindle and axis Z is parallel to it. The direction approaching the workpiece represents the negative direction, whereas the direction leaving it is considered the positive direction.

Based on the relative position between the tool holder and the spindle, a CNC machine tool can have the front tool holder and rear tool holder. The same program instructions in the front tool holder can indicate motion trajectories different from that of the rear tool holder. This system can be used for both front tool holder and rear tool holder. As seen in the following figure, the direction of axis X in the front-tool-holder coordinates is just the opposite to that of the rear-tool-holder ones. In the illustrations and examples provided in this Manual, the front-tool-holder coordinates is referred for explaining the application of the program.

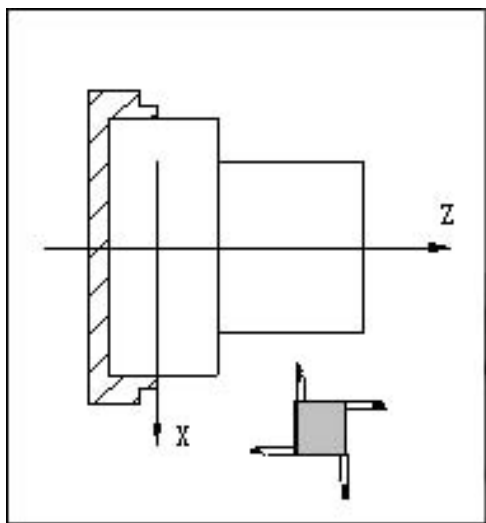

Fig. 1-1-2 Coordinates of Front Tool Holder

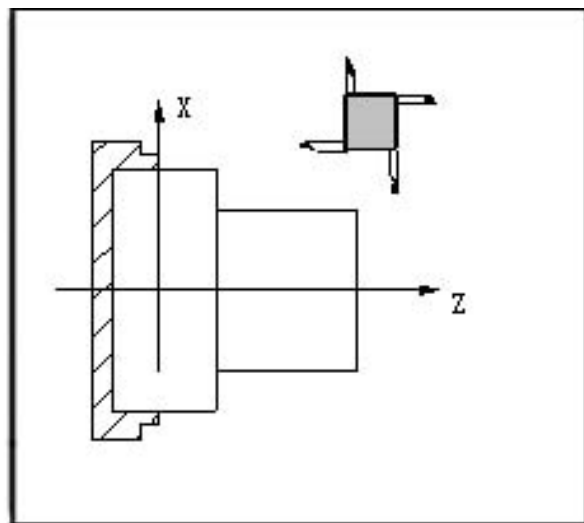

Fig. 1-1-3 Coordinates of Rear Tool Holder

1.3 Coordinates of the machine tool and mechanical origin

The coordinates of machine tool serve as the benchmark coordinates in coordinates computation in a CNC system and is considered the intrinsic coordinates of the machine tool as well. The origin of the coordinates of the machine tool is named as the mechanical reference point or the mechanical origin.

The mechanical origin is determined by the origin switch or reset switch, which is normally installed at the point with the maximum travel in the positive direction of axis X and Z. In executing the mechanical resetting operation, once the system returns to the mechanical origin, it will set the current coordinates of the machine tool as [0,0], which thus establish the machine-tool coordinates that take the current position as the origin.

Note: If no reset switch is installed on the machine tool, it is impossible to execute the mechanical resetting operation.

1.4 Workpiece coordinates and program origin

The workpiece coordinate system, also called floating coordinate system, is the rectangular coordinates set on the drawing of the part for the purpose of programming. After the part is mounted onto the machine tool, instruction G50 will be used to set the absolute coordinates of the tool on the basis of the relative position between the tool and the workpiece, which in consequence sets the workpiece coordinate system in the system. The current position of the tool is called the program origin, to which the system will return after program resetting is performed. Normally, the axis Z in the workpiece coordinate system coincides with the axial line of the spindle, whereas the axis X is located at the head section or end section of the part. Once the workpiece coordinate system is established, it will remain effective, unless it is replaced by a new workpiece coordinate system.

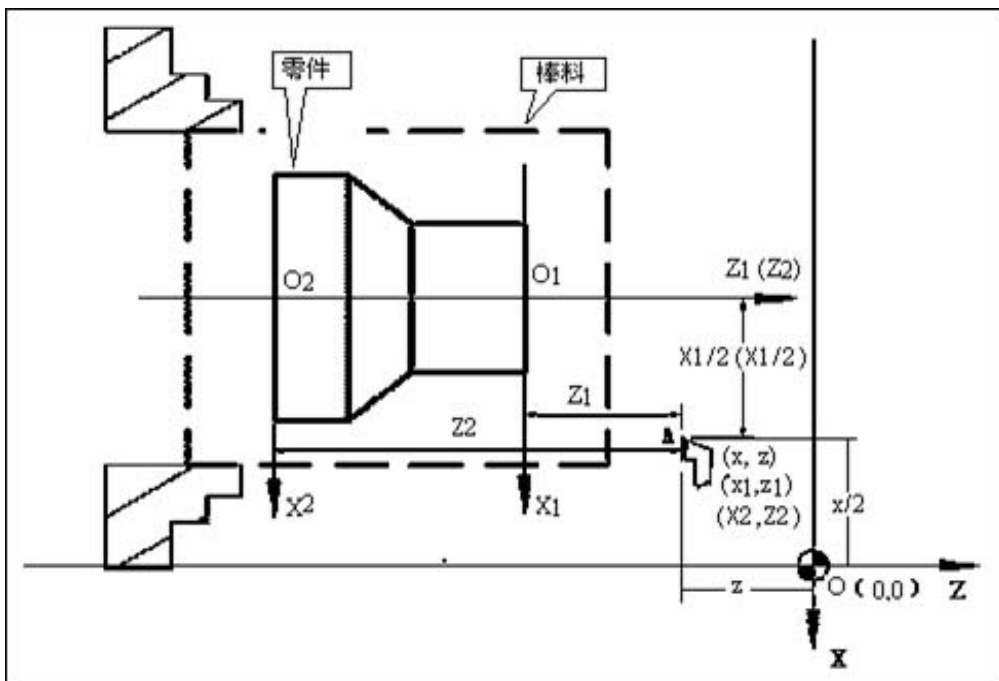

Fig. 1-2-4

In the above figure, XOZ serves as the machine-tool coordinate system, X1O1Z1 as the workpiece coordinate system of the workpiece's head section for axis X, X2O2Z2 as the workpiece coordinate system of the workpiece's end section for axis X, O as the mechanical origin and A as the tool tip. The coordinates of A in the above

three coordinate system can be described as follows:

In the machine-tool coordinate system: A (X,Z);

In the X1O1Z1 coordinate system: A (X1, Y1);

In the X2O2Z2 coordinate system: A (X2, Y2).

Interpolation

Interpolation, also called profile control, refers to the operation with which two or multiple shafts runs simultaneously to create a combined motion locus that complies with the confirmed mathematic relations and to form a of 2D (plane) or 3D (space) profile. In an Interpolation operation, the motion axis is called the linkage shaft, whose motion distance, moving direction and speed are simultaneously controlled in the whole process to form a desired combined motion locus.

If only the end of the motion of one or multiple shafts, not the motion locus, is controlled, such a motion control mode is called point control.

In this system, the axis X and Z serve as the universal driving shaft. This system falls into a CNC system with 2-shaft driving, which provides such functions as linear interpolation, arc interpolation and thread interpolation.

Linear interpolation: The locus of the combined motion of axis X and Z is a straight line extending from the start point to the end point.

Arch interpolation: The locus of the combined motion of axis X and Z is a circular arc whose radius is determined by R or circle cent by I and K, extending from the start point to the end point

Thread interpolation: It refers to the Interpolation between the motion of axis X and Z or of both and the rotary motion of the spindle. F and I instructions provides the pitch of the threads (F is of metric system and I of British system), which refers to the motion distance (no symbol) formed in a thread cutting process when the longer axis (axis X or Z) moves within the time the spindle rotates by once circle. This system can be used to machine straight, tapered and end surface threads in both metric and British systems. However, only when the spindle encoder is installed to the system can threads be machined. If no spindle encoder is installed and the system is operated to machine the thread, the system can't receive signals and thus other operations can't be executed. (It is recommended an encoder with line series over 1000 be used for this system)

1.5 Programming with absolute and relative coordinates

The two ways said below can be used to determine the end point of a locus in programming:

First: Using the absolute coordinates to determine the end point, this is called absolute programming (address of determined position is shown as (X, Z)).

Second: Using the coordinate difference relative to the start point to determine the end point, this is called relative programming (address of determined position is shown as (U, W)). If the relative coordinate is negative value, it means the axis moves in a negative direction, and if a positive value, positive direction.

This system permits the practice with which the absolute coordinate is used for one axis and the relative coordinate for another to indicate the position of the end point of the locus in the same program segment. This is called the mixed programming.

Example: A→B linear interpolation (see Fig. 1-2-5)

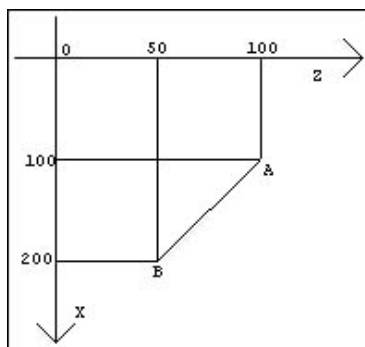

Fig. 1-2-5

Absolute programming: G01 X200 Z50;

Relative programming: G01 U100 W-50;

Mixed programming: G01 X200 W-50 or G01 U100 Z50.

Note: The system will activate the alarm state when both instruction addresses X and U, or Z and WW, appear in the program segment.

For instance: G50 X10 Z20

G01 X20 W30 U20 Z30 【System alarms at the time】

1.6 Conversion between British system and metric system

With G code (G20,G21), the user can make a choice between British system and metric system for the unit.

单位制	G 代码	最小设定单位
英制	G20	0.0001 英寸
公制	G21	0.0001 毫米

System	G code	Min. set unit
British	G20	0.0001 inch
Metric	G21	0.0001 mm

The conversion between British and metric systems should be completed with the separate instruction of program segment in the front of the program before the coordinate system is set. The units of the following value can be changed in accordance with the G code switched over on the basis of British and metric systems.

- (1) Instruction value of feeding speed indicated by F;
- (2) Instruction value related to the position;
- (3) Compensation value;
- (4) Value of one scale on the pulse generator with handwheel;
- (5) Movement of single step;
- (6) Some parameter values.

Note:

1. The G code switched at the time the system is electrified is the same as that

obtained before power-off.

2. Never change G20 and G21 halfway to the running program.
3. When the mechanical unit is different from the entered unit, with a max. tolerance so seen half the min. movement unit, this tolerance won't be cumulated.
4. When switching between the British system (G20) and metric system (G21), make sure the offset is consistent with the new unit.

1.7 Definition of program

To allow the system to machine the part automatically, the user should first compile the part's program (shortened as "program") in accordance with the instruction format provided by the CNC system. To machine the part, the CNC system runs the program to allow the machine too to complete such actions as feeding motion, spindle starting and stopping, tool selecting, cooling and lubricating.

Example:

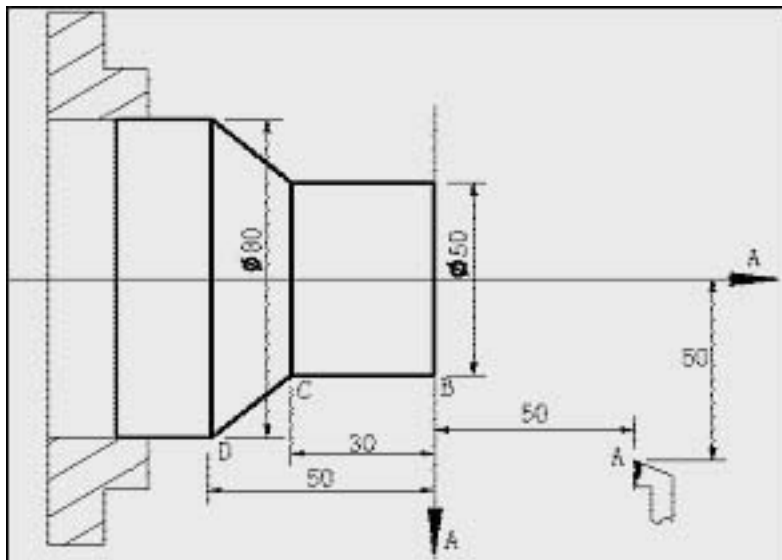

Fig. 1-3-1

```

O0001: (program name)
G0 X100 Z50: (fast position to point A)
M12: (clamp the workpiece firmly)
T0101: (change to tool 1 to execute tool offset No. 1)
M3 S600: (start the spindle and set the spindle speed as 600r/min)
M8 (turn on the coolant)
G1 X50 Z0 F600: (approach point B at the speed of 600mm/min)
W-30 F200: (cut from point B to C)
X80 W-20 F150: (cut from point C to D)
G0 X100 Z50: (fast retract to point A)
T0100: (cancel tool offset)
M5 S0: (stop spindle)
M9: (turn off coolant)
M13: (loosen workpiece)
M30: (program ends, turn off spindle and coolant)
%
```

Once the aforesaid procedures are completed, the tool will create a locus with following path: A→B→C→D→A

1.8 Composition of program

A program consists of several segments which begin with the head “OXXXX” (program name) and end with “%”. The program segment name is made up of the beginning program segment number (can be omitted), and several instruction characters such as“;” and “*”. The regular structure of a program can be seen in Fig. 1-3-2 as follows:

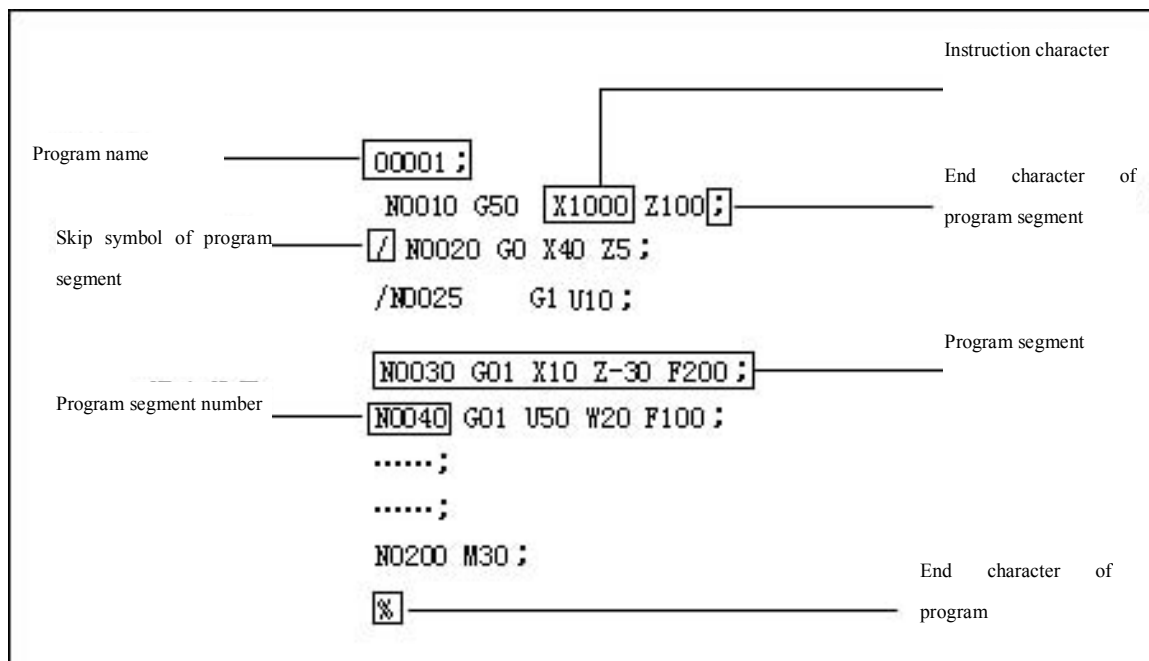
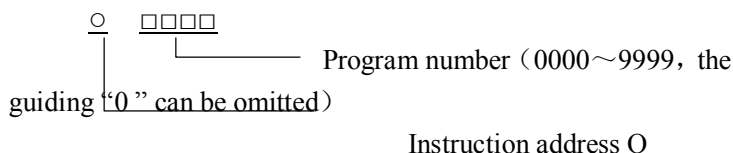

Fig. 1-3-2 Regular Structure of a Program

1) Program name

To identify a program, at the beginning of each program is the program name consisting of the instruction address O and the four-digit number following it. The system can save 9999 programs maximally, no two of which are identical to each other.



2) Instruction character

The instruction character serves as the basic instructing unit that commands the CNC to complete the control process, which normally consists of one English letter (called instruction address) and the numeric values (called instruction value or symbol-free number) following it. The instruction address defines the meaning of the instruction behind. In different combination of instruction characters, the same

1.9 Main program and subroutine

To simplify programming, when identical or similar machining locus or control process needs to be used frequently, the program instructions of this part can be compiled as separate program and then called. Thus, the program that calls other programs is named as main program, whereas the called programs (ending with M99) are named as subroutine. Both subroutine and main programs can consume the program capacity and the memory space. A subroutine can also have its independent program name and can be called by any main program, or run independently.

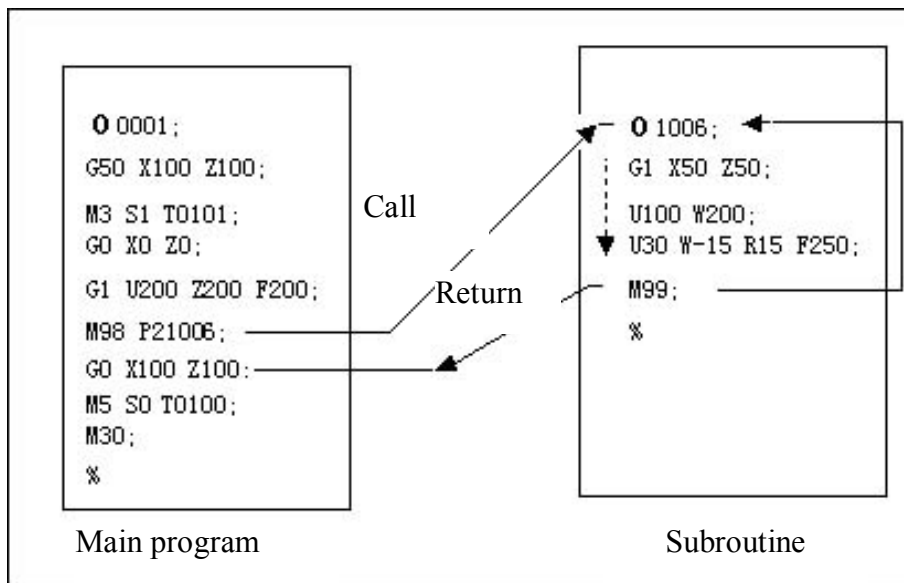
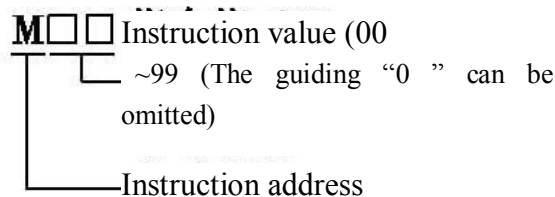

Fig. 1-3-3

2. MSFT Instructions

2.1 Auxiliary functions (M instruction)

An M instruction, composed of the instruction address M and the 1-2-digit numeric number following it, is used to control the flow of program execution or to output signal to the machine tool.



Only one M instruction can be effective for each program segment. If there are two or

more than two M instructions in one program segment, only the last M instruction will become effective.

When S instruction shares the segment with the instruction characters executed for motion, the order of execution can be described as follows:

- (1) When M instruction is M00, M30, M98 or M99, the M instruction should be executed after the motion is completed.
- (2) When M instruction is used to output signal to the machine tool, the M instruction and motion instruction should be executed simultaneously.

List of M Instructions

Instruction	Function	Remarks
M00	Program pause	State not retained
M30	Program running end	
M98	Subroutine call	
M99	Return from subroutine	
M03	Spindle rotates positively	Function interlocked, state retained
M04	Spindle rotates negatively	
*M05	Spindle stop	
M08	Coolant pump on	Function interlocked, state retained
*M09	Coolant pump off	
M10	Tailstock advance	Function interlocked, state retained
M11	Tailstock retract	
M12	Chuck nip	Function interlocked, state retained
M13	Chuck loose	
M32	Lubricant on	Function interlocked, state retained
*M33	Lubricant off	
M40	Level setting output off	
M41	Speed output of level 1	
M42	Speed output of level 2	
M43	Speed output of level 3	
M44	Speed output of level 4	
M88	Detecting signal of the designated input pin	It can be designated the effective electric level be input.
M89	Switch control over the designated output pin	It can be designated the electric level be output.

Note: Instructions with the mark “*” can become effective when the system is electrified.

After the system executes the M instruction through the signal sent to the machine tool, it will execute the follow-up instruction characters or program segment with a time delay. This delayed time can be set through the M code in the system parameters.

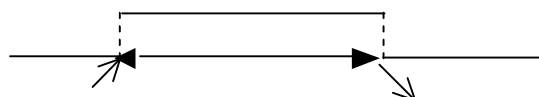

Starts executing M code Delayed time
Execute the follow-up instruction characters or program segment

2.1.1 Subroutine call (M98)

Instruction format:

M98 P○○○ □□□□

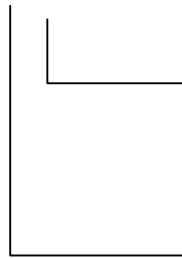

The subroutine number to be called is 0000~9999. When the number of calling times is not entered, the guiding "0" of the subroutine number can't be omitted. When the number of calling times is entered, the subroutine number must be four-digit figure.

The times of calling should be 1-999. When it is only called once, it doesn't need to be entered.

Definition: When other instructions of the program segment are executed, the system won't execute the next program segment, but the program segment designated by P. A subroutine can only be executed for 999 times at maximum. In MDI state, the subroutine can't be called.

2.1.2 Return from subroutine and to main program (M99)

Instruction format: M99 P○○○ (return from subroutine)

Definition: When the called subroutine is executed, the system will return to segment designated by P in the main program. If P is not entered, the system will return to the main program to call the program segment behind M98 of the current subroutine. If M99 is used for ending the main program (e.g. the current is not executed by calling other programs), the current program will be executed repeatedly. In MDI state, M99 becomes effective.

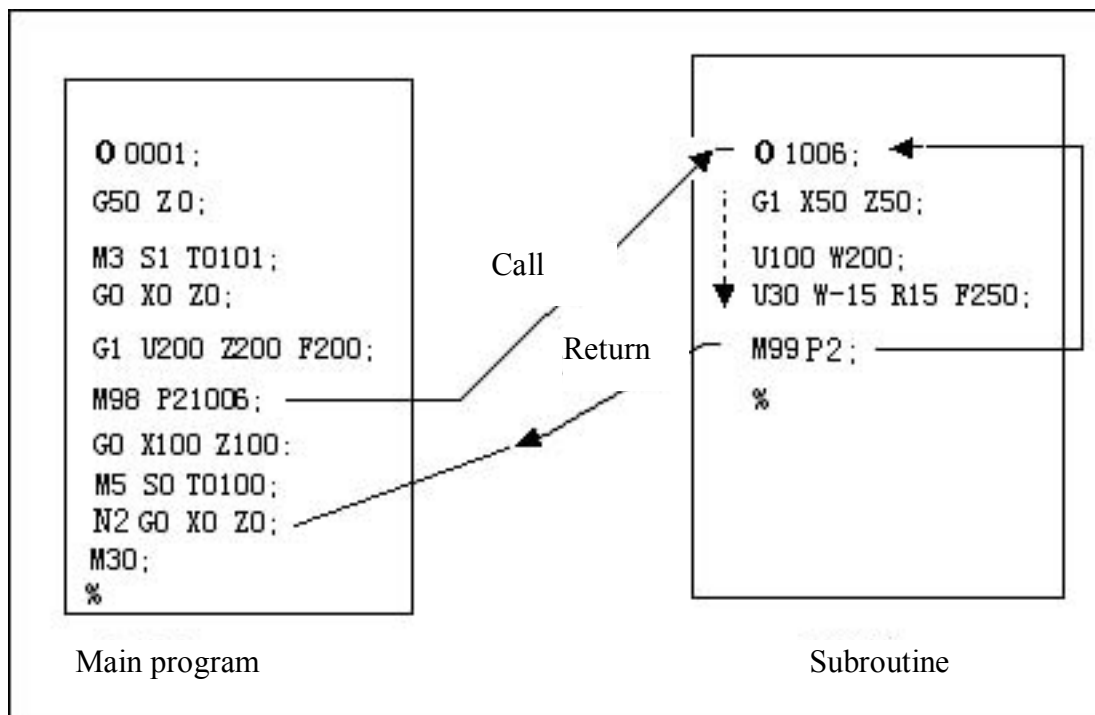

Fig. 2-1-4 Return from Subroutine

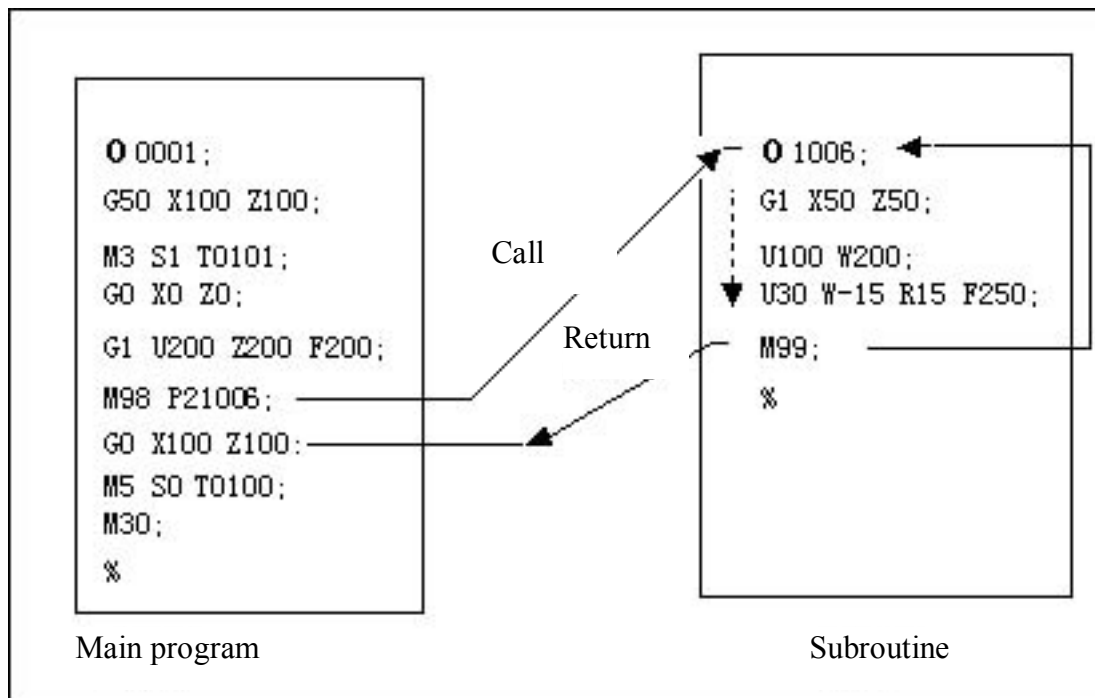

Fig. 2-1-4B Return to Main Program

This system can call the subroutine of nine folds. In other words, it can call other subroutines in a subroutine. (See the figure)

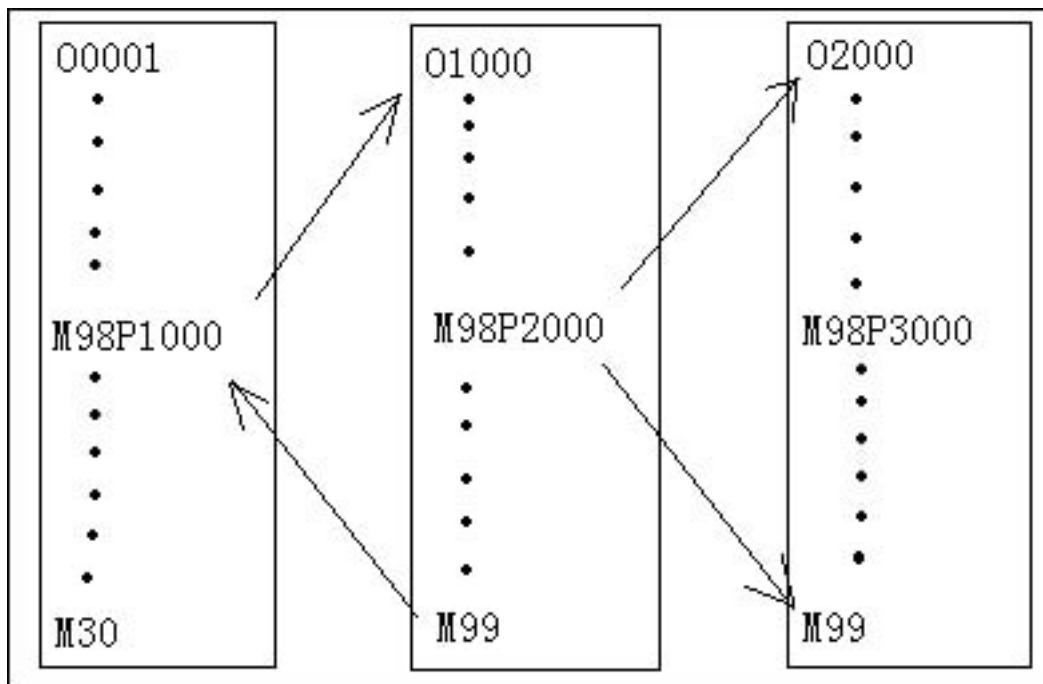

Fig. 2-1-3 Nesting Call of Program

2.1.3 Spindle control (M03, M04 and M05)

Definition: M03 or M3: Spindle rotates positively;
M04 or M4: Spindle rotates reversely;
M05 or M5: Spindle stops.

When the system is electrified, the output of M05 is effective. If so, the system will execute M03 or M04. At the time, the output of M03 or M04 is effective and retained, and output of M05 is canceled (effective output). When the output of M03 or M04 is effective, the system will execute M05 and output of M03 or M04 canceled. Output of M05 is effective and retained.

When the output of M03 or M04 is effective, the system will execute M04 or M03 and send out alarm signal.

Note: In emergency stop state, the output of M03 and M04 is canceled and output of M05 is effective.

2.1.4 Coolant control (M08 and M09)

Definition: M08 or M8: Coolant pump on;
M09 or M9: Coolant pump off.

When the system is electrified, the output of M09 is effective and output of M08 is ineffective. If the system will execute M08, the output of M08 will be effective, and at the time, the coolant is turned on. If the system will execute M09, the output of M08 will be canceled, and at the time, the coolant is turned off

Note1: In emergency stop state, the output of M08 is canceled.

Note2: When M09 has not corresponding output signal, if the system executes M09, the output of M08 will be canceled.

2.1.5 Tailstock control (M10 and M11)

Definition: M10: Tailstock advance;
M11: Tailstock retract.

When the system is electrified, both M11 and M10 have no output. If the system executes M10, the output of M10 will become effective, output of M11 will be canceled, and the tailstock will advance. If the system executes M11, the output of M11 will become effective, output of M10 will be canceled, and the tailstock will retract.

Note: In resetting and emergency stop state, the output state of M10 and M11 remain unchanged.

2.1.6 Chuck control (M12 and M13)

Definition: M12: Chuck nip;
M13: Chuck loose.

When the system is electrified, both M12 and M13 have no output. If the system executes M12, the output of M12 will become effective and the output of M13 canceled. If the system executes M13, the output of M13 will become effective and the output of M12 canceled. M12 and M13 can be effective simultaneously.

Note 1: In resetting and emergency stop state, the output state of M12 and M13 remain unchanged.

Note 2: The chuck can be controlled by the signal input from the external device.

2.1.7 Lubricant control (M32 and M33)

Definition: M32: Lubricant on;
M33: Lubricant off.

When the system is electrified, M33 becomes effective, in other words, the output of M32 becomes ineffective. If the system executes M32, the output of M32 will become effective and the coolant pump will be turned on. If the system executes M33, the output of M32 will become canceled and the coolant pump will be turned off.

Note 1: In emergency stops state, the output of M32 will become ineffective.

Note 2: When M33 has not corresponding output signal, if the system executes M33, the output of M32 will be canceled.

2.1.8 Program pause (M00)

Instruction format: M00 or M0

Definition: After other instructions of the current program segment are executed, the program will pause. At the time, press the start button, the system will run the next program segment.

2.1.9 Program end and return (M30)

Instruction format: M30

Definition: After other instructions of the current program segment are executed, the program will stop automatically. At the time, the system executes M05 and M09, and the number of parts to be machined increases by 1 simultaneously. And the cursor returns to the beginning of the program. (It depends on the system's parameters whether the cursor returns to the beginning of the program. When the system's parameter No.67 is 0, the cursor won't return to the beginning, when 1, it will.)

2.2 Programmable input/output instructions

2.2.1 Programmable input instruction (M88)

Definition: To allow the user to self-define the input point\

Instruction format: M88 Pxx Lx Qxxxx

P is used to set the value of the output port number: 1-24 (subject to the nature of the controller)

L is used to set the effective input level: "1" means high effective level, "0" means low effective level.

Q is used to set the detection time, with unit as "second".

Note 1: If no set level is detected within the time set by Q instruction, the system will send out alarms to prompt the user "input signal overtime".

Note 2: If Q instruction is not set, the system will enter the default state that permanently waits for input signal. It won't execute the next instruction until the effective signal is received.

Note 3: If the set port number is not within the range 1-24, the system will send out alarms to prompt the user "IO port number exceeded".

Note 4: If P instruction is not compiled, the system will send out alarms to prompt the user "port number not available".

2.2.2 Programmable output instruction (M89)

Definition: To allow the user to self-define the output point.

Instruction format: M89 Pxx Lx

P is used to set the value of the output port number: 1-24 (subject to the nature of the controller)

L is used to set the effective input level: "1" means high effective level, "0" means low effective level.

Note 1: If the set port number is not within the range 1-24, the system will send out alarms to prompt the user "IO port number exceeded".

Note 2: If P instruction is not compiled, the system will send out alarms to prompt the

Program:	
O0001:	(program name)
M3 S300:	(spindle rotates positively)
G0 X100 Z50:	(fast move to point A)
G0 X50 Z0:	(fast move to point A)
G1 W-30 F200:	(cut from point B to C)
X80 W-20 F150:	(cut from point C to D)
G0 X100 Z50:	(fast retract to point)
M30:	(program ends, turn off spindle and coolant)
%	

2.3.3 Spindle magnification

When the analog voltage mode is activated to control the spindle speed, the actual spindle speed can be regulated through the magnification key with a range 50%~120% and by eight levels in a real-time manner. (Each level changes 10% of the value)

The actual speed regulated through magnification key is subject to the max. speed value of the current level, as well as by min. speed value. The magnification won't be saved at the time of power interruption, and the initial magnification is 100% at the time the system is electrified.

2.3.4 Constant linear speed control (G96) and constant rotation speed control (G97)

Instruction format: G96 S__;(S0000-S9999, guiding 0 can be omitted);

Definition: To make the constant linear speed control effective, set the linear speed for cutting (m/min) and give up the control for constant rotation speed. G96 serves as mode G instruction. If the current state is of G96 mode, you don't need to enter G96.

Instruction format: G97 S__;(S0000-S9999, guiding 0 can be omitted);

Definition: To give up the constant linear speed control, make the constant speed control effective and set the speed of the spindle (m/min). G97 serves as mode G instruction. If the current state is of G97 mode, you don't need to enter G97.

When the lathe cuts the workpiece, the workpiece will rotate with the spindle's axial line as its center line. The point cut by the tool on the workpiece can form a circular movement along the spindle's axial line, and the momentary speed along the tangent direction of the circle is called "linear speed for cutting" (normally shortened as linear speed).

Only when the regulation of spindle speed through analog voltage is enabled, can the control of constant linear speed become effective. In regulating the constant linear speed, the spindle speed will vary according to the change of absolute coordinate of axis X on the programming locus (tool length offset omitted). When the coordinate value of axis X increases, the spindle speed will decrease, and when the coordinate value decreases, it will increase. In this way, the linear speed for cutting can retain the S instruction value.

Linear speed=Spindle speed *|X|*π/1000 (m/min)

In regulating the constant linear speed, the axis Z of the workpiece's coordinate system must coincide with the spindle's center line. Otherwise, the actual linear speed will be inconsistent with the set linear speed.

2.3.5 Limit of spindle's max. speed

With the follow-up values of G50S, the user can set the max. speed (r/min) of the

spindle with constant linear speed control: G50 S___;

In regulating the constant linear speed, if the spindle speed is higher than the value set in aforesaid program, it will be limited to the max. spindle speed.

2.4 Quick move and feed (G98/G99, F instruction)

Three motion control modes are available in this Manual, which are quick move, cutting feed and manual feed.

2.4.1 Quick move

Quick move: As for a lathe, as the quick movement along axis X is separated from that along axis Z, the motions of the two directions can't form a fixed straight line or circular arc. In this system, quick move can be realized through both G instruction and manual operation. In the case of manual quick move, the system can't move along both axis X and axis Z simultaneously.

The quick move rate of both axis X and Z can be set through the related system parameters. The magnification key can be used to regulate the quick move rate in a real-time manner. The actual quick move magnification can be set as 25%, 50% or 100% of the initial value. The quick move magnification won't be saved at the time of power interruption, and the initial magnification is 100% at the time the system is electrified.

2.4.2 F instruction for cutting feed

Cutting feed: In this state, the system controls motions of both axis X and Z to make the locus of the tool's motion consistent with that defined by the instruction (line, circle and arc), and the same time, the instantaneous speed of the motion locus along the tangent is consistent with value defined by F instruction. This motion control process is called cutting feed or interpolation. The speed of cutting feed is defined by F instruction. When the system executes the interpolation instruction (cutting feed), the cutting feed speed defined by F instruction will be distributed to the two directions of axis X and Z in light of the programmed locus. Meanwhile, the system controls the instantaneous speed along both axis X and Z, so as to make the vector-resultant speed of these two directions equal to the value of F instruction.

Remarks: To regulate the feed speed in a real-time manner, the user can use the magnification key on the control panel of the machine or a magnification switch externally connected. The feed speed can be regulated within the scope of 0~150% of the initial value by 16 levels (each level changes 10% of the value). The regulation of feed magnification is ineffective to the thread cutting.

$$F = \sqrt{f_x^2 + f_z^2}$$

$$f_x = \frac{dx}{dt}$$

$$f_z = \frac{dz}{dt}$$

Where,

F refers to the vector-resultant speed of instantaneous value along both axis X and Z.

Dx refers to the instantaneous (dt segment) increment of axis X, fx to instantaneous

speed of axis X.

Dx refers to the instantaneous (dt segment) increment of axis X, fx to instantaneous speed of axis X.

Example: In Fig. 2-2-6, the figures in the bracket are the coordinate values of each point (diameter value along axis X).

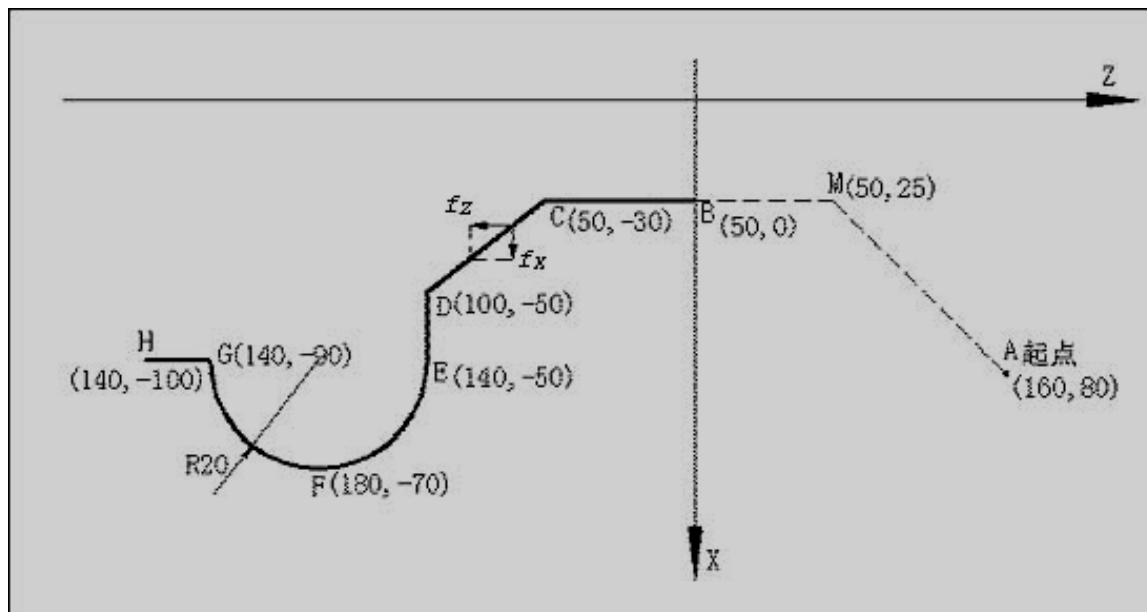

FIGURE 2-3-2

Program:

```

O0010:
G00 X160 Z80: (first move the machine tool to a safe
position)
G98:
G0 X50 Z0: (quick move from A through M to B)
G1 W-30 F250: (B→C)
X100 W-20: (C→D)
X140: (D→E)
G2 W-40 R20: (EFG arc interpolation)
W-10: (G→H)
M30:
%
```

2.4.1. G98, G99

Instruction format: G98 Fxxxx; (F0001~F8000, guiding 0 can be omitted, set feed speed per minute, with unit mm/min)

Definition: To set the cutting feed speed with unit mm/min. G98 serves as a mode G instruction. If the current state is of G98 mode, you don't need to enter G98.

Instruction format: G99 Fxxxx (F0.0001~F500, guiding 0 can be omitted)

Definition: To set the cutting feed speed with unit mm/min. G99 serves as a mode G instruction. If the current state is of G99 mode, you don't need to enter G99. When the

system executes G99 F_{xxxx} , it will take the product between F instruction value (mm/r) and the current spindle speed (r/min) as the set value to control the actual cutting feed speed. When the spindle speed changes, the actual cutting feed speed changes too. When G99 F_{xxxx} is used to set the cutting feed for each round of the spindle, even cutting grain can be achieved on the surface of the workpiece. When parts are machined in G99 mode, the machine tool must be equipped with an encoder for the spindle.

G98 and G99 are of mode G instructions of the same group, only one of which can be effective. The G98 serves as G instruction of initial state. And in default state, G98 is effective.

Note: In G99 mode, when the spindle speed is lower than 1 r/min, the cutting feed speed may become uneven. If the spindle speed fluctuates, the actual cutting feed speed varies accordingly. To ensure the product quality, it is recommended that the selected spindle speed not be lower than the min. value the spindle servo or frequency converter needs to output an effective torque.

2.4.4 Manual feed

Manual feed: In this system, positive/negative move along axis X or Z can be realized in accordance with the current manual feed speed when in manual mode. However, simultaneous move can be achieved between axis X and Z. The actual manual speed along axis X and Z can be regulated within a range 0~150% through the magnification key in a real-time manner. The manual speed of each level is the product between the fixed value set in the system parameters and the manual magnification.

The manual feed magnification won't be saved at the time of power interruption, and the initial magnification is 100% at the time the system is electrified.

Automatic acceleration and deceleration

At the time the shafts begin to move and stop moving, the system will work as such that shafts are accelerated or decelerated in an automatic manner, so as to realize the smooth speed transition and minimize the strike caused at the time of start and stop.

Linear acceleration mode is adopted in this system.

Quick move: Initial speed of axis X

Initial speed of axis Z

Acceleration/deceleration time of axis X

Acceleration/deceleration time of axis Z

Cutting feed: Feed speed

Initial feed speed

Acceleration/deceleration time for feeding

For details, please refer to the parameters setting at the related operating instructions.

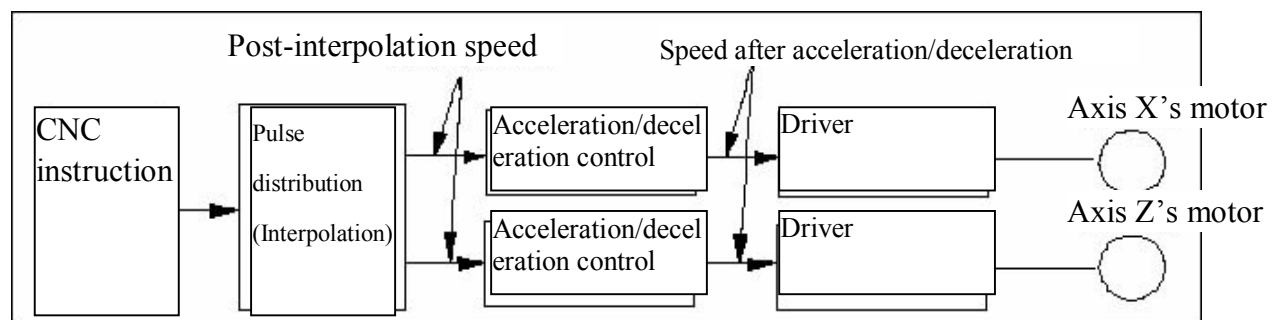

Fig. 2-3-3

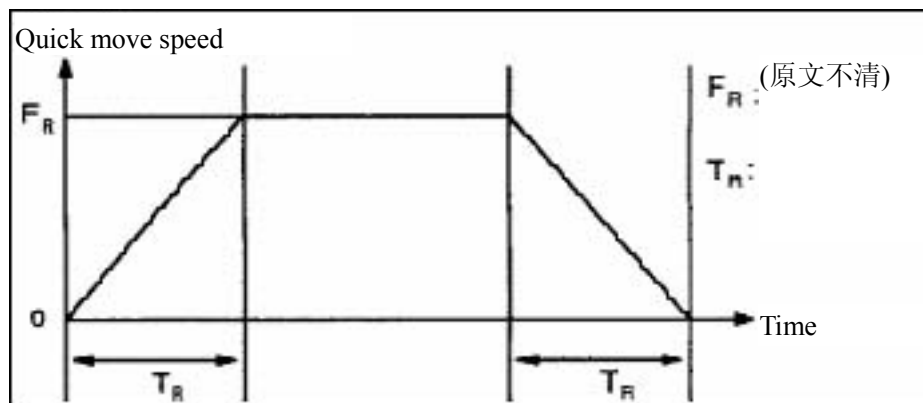

Fig. 2-3-4 Curve of Quick Move Speed

2.5 Tool offset (T instruction)

This system can perform automatic tool change. For that purpose, the automatic tool rest with 4~8 tools can change the tool in the process of machining, thus realizing the function with which multiple processes and tools can be engaged in the machining of parts.

This system can also provide the function of tool-length offset, with which the user doesn't need to consider the tool's actual position in compiling the program, but obtain the offset data of each tool (called tool offset) before machining. Before using the tool, the user should complete the length offset of tool. In other words, the user may offset the tool in accordance with the coordinates of the tool offset value relative to the system, so as to make the motion locus of the tool tip consistent with the programmed one. When the tool needs to be replaced, what the user should do is to modify the tool offset, but not the machining process. If size difference of machining appears because of the worn state of the tool, the user can directly modify the tool offset according to the size difference, so as to eliminate such errors.

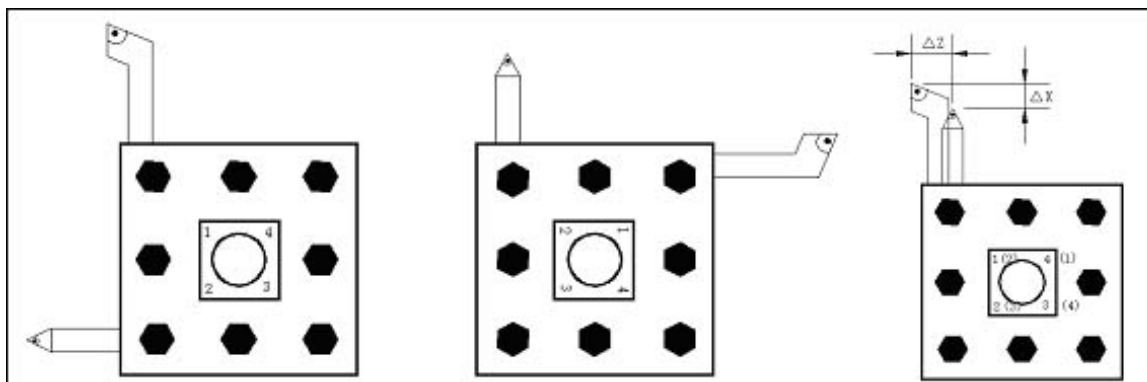
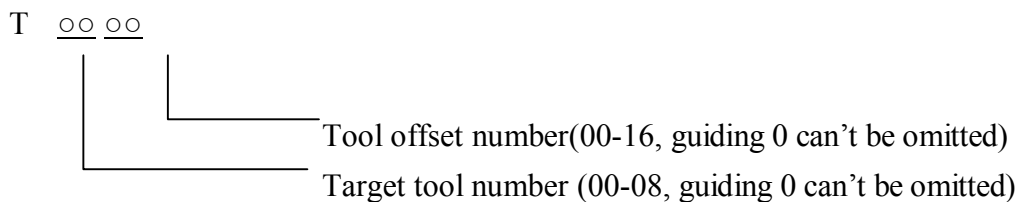

Fig. 2-4-1

Instruction format:



Definition: To allow the automatic tool rest to replace the tool with that of the target tool number and perform tool length offset in accordance with the offset corresponding to the offset number. The tool offset number can be either identical with or different from the tool number. In other words, one tool can have multiple offset numbers. The tool offset with an offset number 100 can be as $X=0, Z=0$, which means the system is in a non-tool offset state because the coordinate deviation of the system is 0 (no coordinate deviation). When the tool length offset is completed, execute $T\ \square\square00$, and the system will reversely move its coordinates in accordance with the current tool offset. At the time, the state of executed tool length offset changes to non-offset state, with the displayed tool number as 100. This process is called canceling tool length offset, normally shortened as “cancel tool offset”.

For example: T0101 means tool 1 is selected and tool offset 1 is executed;

T0102 means tool 1 is selected and tool offset 2 is executed;

T0301 means tool 3 is selected and tool offset 1 is executed.

When the system is electrified, what's displayed for T instruction is the pre-electrification state of the tool number and offset number.

Only one T instruction can be effective for each program segment. If there are two or more than two T instructions in one program segment, only the last T instruction will become effective.

If any of the following operations is performed, the system will cancel the tool length offset:

1. Instruction $T\ \square\square00$ is executed;
2. Instruction G28 or manual mechanical resetting is executed (Only the tool length offset of the axis where the system has returned to the mechanical origin is canceled, not where the system hasn't returned to the mechanical origin.)
3. Program resetting is executed (Only the tool length offset of the axis where the system has returned to the program origin is canceled, not where the system hasn't returned to the program origin.)

When T instruction shares the segment with the instruction characters executed for motion, the tool-change instruction will be executed before the motion instruction.

The tool length offset is based on the programmed locus. Offset corresponding to its tool offset number in T instructions will be added or deducted at the end of each program segment. Fig. 2-4-2 shows the creation, execution and cancellation of tool length offset

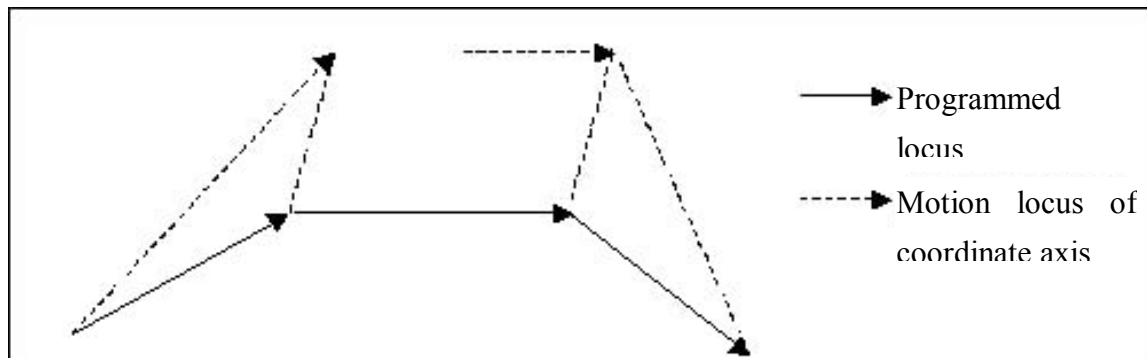

Fig. 2-4-2 Creation, Execution and Cancellation of Tool Length Offset

G01 X100 Z100 T0101: (Program segment 1, procedure to execute the tool length offset)

G1 W150: (Program segment 2, state of tool length offset)

G1 150 W100 T0100: (Program segment 3: cancel tool length offset)

When T instruction shares the segment with the instruction characters executed for motion, the speed of cutting advancement, either fast or slow, with which the tool length offset is executed, is determined by the motion instruction.

When the line-tool rest (no automatic tool post is installed) is used, the system parameter—tool number, should be set as 0. At the time, the tool path is 0, and there is no action of tool change at the time of executing the T instruction, but the execution of tool length offset. Thus the cutting tool is virtually changed through execution of tool length offset.

This system suits the application of tool rest with 4-8 tool paths. It works as such that the tool path signal is directly entered (each tool path signal is independent), the tool rest rotates positively to change the tool and the tool is locked once it reaches the proper position.

3. G Instruction

3.1 Overview

A G instruction, consisting of instruction address G and a 1~2-digit value behind it, is used to define the Interpolation mode, pause, coordinate setting and so on, where the tool is in a position relative to the workpiece.

G □□
 ┌───┐
 │ │
 └───┘
 Instruction value(00~99, guiding 0 can be omitted)

Instruction address G

The G instruction characters comprise of four groups, namely, 00, 01, 02, 03 and 04. G instruction characters of different groups can be entered into the same program segment. If more than two G instruction characters of the same group are entered into the same program segment, only the last G instruction character is effective. G instruction characters of different groups without shared parameters (instruction character) can be used in the same program segment, and they can function simultaneously, regardless of what order they are arranged. The system doesn't support G instruction characters other than those listed in the table, and if a foreign character is instructed, the system will send out alarms.

3.1.1 Mode, non-mode and initial state

The mode function refers to the factor that once one code is defined in the current program segment, it will be effective before another code of the same group appears in the same segment, and no other code needs to be defined if the next program segment is used again.

The non-mode function means one code only functions in the program segment where it is. The code must be defined again if it is used for the next segment.

At the time the system is electrified, mode G instruction characters whose functions are not executed or state not enabled are called initial G instruction characters. When an initial G instruction is executed after electrification, this G instruction character doesn't need to be entered. The initial instruction characters of this system are G00.

3.1.2 Definitions

The contents related to the items below are defined as:

Start point: Position where the current program runs;

End point: Position where the running of the current program ends;

X: End point's absolute coordinate along axis X;

U: Difference between absolute coordinate of end point and that of start point along axis X;

Z: End point's absolute coordinate along axis Z;

W: Difference between absolute coordinate of end point and that of start point along axis Z;

F: Speed of cutting feed

Table of G Instructions

Instruction character	Group	Definition	Remarks
G00	01	Quick move	Initial G instruction
G01		Linear interpolation	Mode G instruction
G02		Arch interpolation (clockwise)	
G03		Arch interpolation (counter-clockwise)	
G32		Thread cutting	
G90		Axial cutting cycle	

G33		Axis Z tapping cycle	
G92		Thread cutting cycle	
G94		Radial cutting cycle	
G04	00	Pause, stop	Non-mode G instruction
G20		Input unit of British system	
G21		Input unit of metric system	
G27		Instruction to check whether the system returns from the reference point	
G28		Returns to the mechanical origin	
G29		Instruction for returning from the reference point	
G30		Instruction for returning to the second reference point	
G50		Setting coordinate system	
G70		Fine machining cycle	
G71		Axial rough machining cycle	
G72		Radial rough machining cycle	
G73		Enclosed cutting cycle	
G74		Axial slot-cutting multiple cycles	
G75		Radial slot-cutting multiple cycles	
G96		02	
G97	Constant linear speed off		Initial G instruction
G98	03	Feed per minute	Initial G instruction
G99		Feed per round	Mode G instruction

3.2 Interpolation

3.2.1 Quick move (G00)

Instruction format: G00 X (U)Z(W);

Definition: To allow axis X and Z to move from the start point to the end point in a quick mode. G00 serves as a mode G instruction.

It should be noted that, as the two axes move at different speed, their combined locus may not be a straight line and they may not arrive at the end point simultaneously.

The instruction addresses, X (U), Z (W) can be omitted, or one of them can be omitted. If one is omitted, it means the coordinates on this axis are the same as that

of the end point. If two are omitted, it means the start point and the end point coincide with each other.

The quick move rate of both axis X and Z can be set through the related system parameters. The actual quick move rate can be regulated through the magnification key on the control panel of the machine tool.

The maximum speed the machine tool can reach is subject to the condition of the product and the supporting motor. For details of the parameters, please refer to the User Manual provided by the manufacturer.

G00 is a mode instruction, no need to be entered again when the next segment is the same.

G00 can be replaced by G0, the two of which provide the same effects.

To avoid tool collision, when sending instructions to move axis X and Z simultaneously, the operator should pay close attention to see whether the tool is within the safe area.

Example: Tool moves from point A to point B in a quick mode.

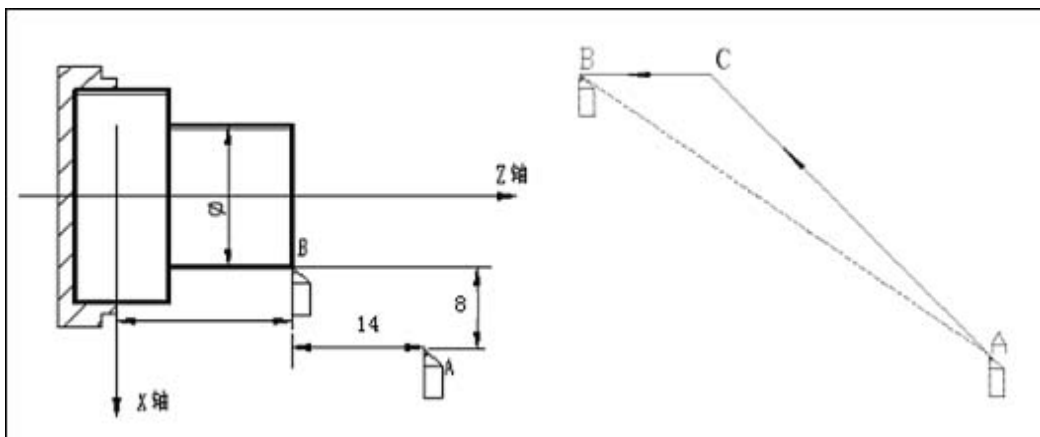

G0 X20 Z25 (coordinate of point A)

G0 U-8 W-14 (A→B)

3.2.2. Linear interpolation (G01)

Instruction format: G01 X (U)_ Z (W)_ F_;

X (U) /Z (W): Absolute or relative coordinate value of the end point

F: Cutting feed speed

Definition: Instruction G01 allows the tool to move along the tie line between the current point to a point defined by X (U), Z (W) and reaches the position designated. The motion locus is a straight line between the start point and the end point. F instruction value is the vector-combined value of the instantaneous speed along axis X and Z. The actual cutting feed is product between the feed magnification and F instruction value. Once F instruction is executed, the instruction value will be retained before a new F instruction is executed.

Example:

G01 X60.0 Z-25 F200; (absolute value programming)

G01 U20.0 W-25.0; (relative value programming)

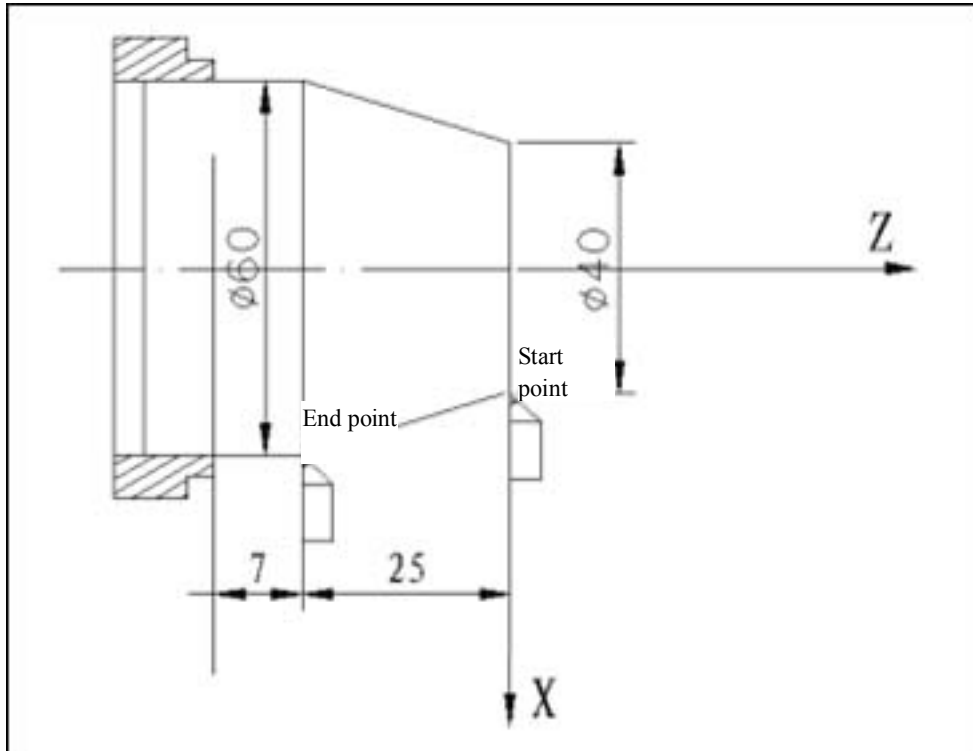

3.2.3 Arc interpolation (G03 and G02)

Instruction format: G03/ G02 X(U)_ Z(W)_ R_ (I_ K_) F_;

Definition: Its motion locus is a clockwise or counterclockwise circular arc from the start point to the end point, as shown in the figure below.

R: Arc radius (0~9999.999mm);

I: Difference between the center of circle and coordinates of arc's start point on axis X (-9999.999~9999.999mm)

K: Difference between the center of circle and coordinates of arc's start point on axis Z (-9999.999~9999.999mm)

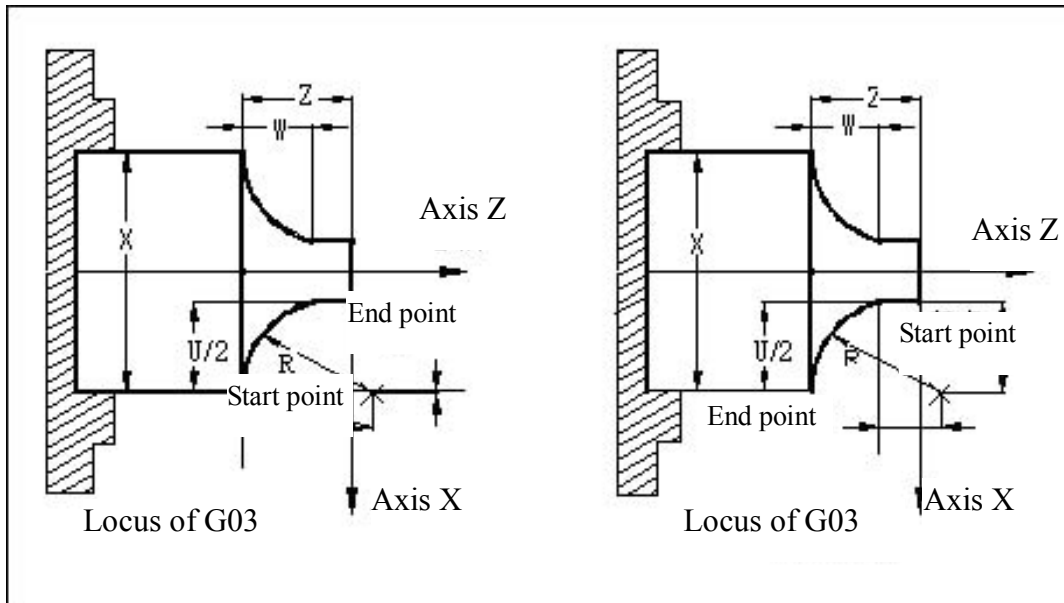

Fig. 3-4-1

Example: Seen Fig. 3-4-2 below

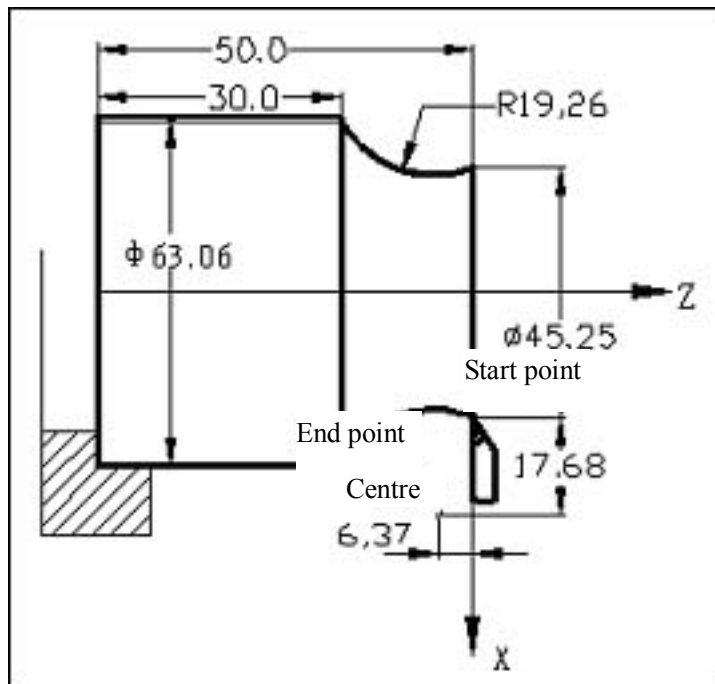

Fig.3-4-2

Program:

```
G02 X63.06 Z-20.0 R19.26 F300;
Or G02 U17.81 W-20.0 R19.26 F300;
Or G02 X63.06 Z-20.0 I35.36 K-6.37 F300;
Or G02 U17.81 W-20.0 I35.36 K-6.37 F300;
```

Precautions:

- One of the instruction addresses in G02/G03 program segment, namely, I, K

and R, must be entered. Otherwise, the system will alarm. If three of them are entered at the same time, only R will be effective, and I and not effective. If R is not entered or R's value is zero, the system will alarm.

- If X (U) and Z (W) are not entered and R is used to define the radius, axis X and Z won't move when instruction G02/03 is executed. If R is not entered and I and K instructions are executed, the locus created by executing G02/G03 will be a full circle (360°);
- If R instruction R is used, the loci would be two circular arcs, one over 180° and the other less than 180°. In defaults of this system, circular arc less than 180° will be effective (see Fig. 3-4-3). If the end point is not on the arc defined by R, the system will alarm.

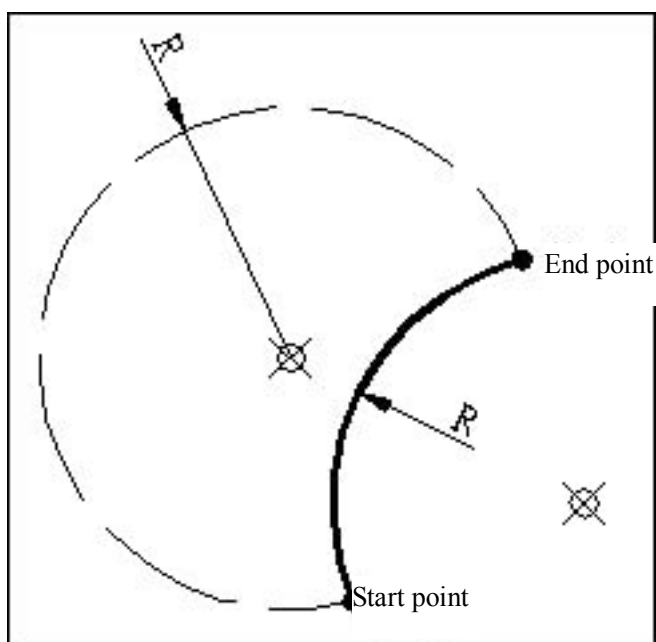

Fig. 3-4-3

- When in G02/G03 program segment I and K instruction characters are used to define the center of circle, even if the end point is not on the circular arc, the system won't alarm. The locus can be described as: Based on the center of circle, it moves along the circular arc on both axis X and axis Z. When the coordinates on axis X is the same as that on axis Z, axis X or axis Z will stop moving, and the other axis (axis Z or axis X) will go on moving till the end point is reached. See Fig. 3-4-4 below.

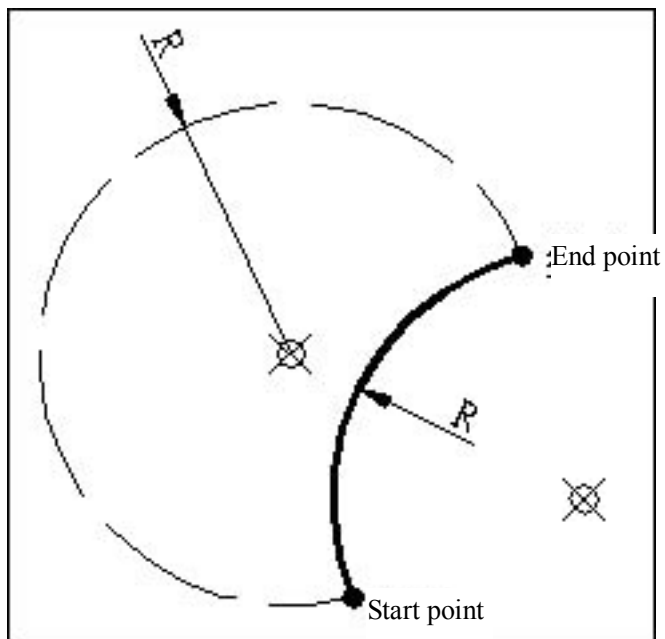

Fig. 3-4-4

3.2.4 Pause (G04)

Instruction format: G04 P__;
 Or G04 X__;
 Or G04 U__;

Definition: When the motion of each axis stops, it won't change the current G instruction mode and retained data and state. When the delayed time is used up, the system will execute the next program segment. The delayed time is defined by instruction character P__, X__ or U__. G04 serves as the non-mode G instruction.

3.2.5 Check of returning from reference point (G27)

Instruction format: G27 X/U Z/W
 X/U: Coordinates of the reference point
 Z/W: Coordinates of the reference point

Definition: To improve the reliability of the machining and accuracy of the machined size, G27 can be used to check whether the program origin is correct and what the positioning errors may be.

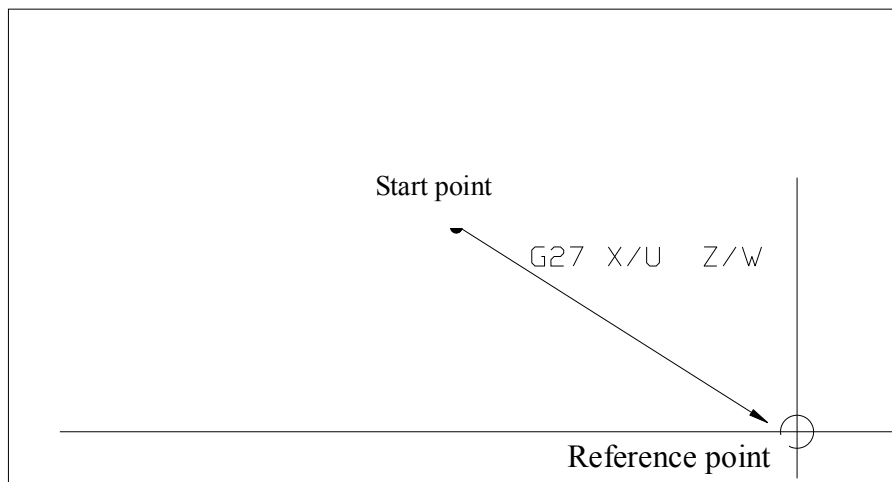

Note:

- 1) Execution of instruction: When this instruction is executed, the designated shaft will be quickly positioned in light of the defined coordinate values, and at the same time, the system will check the switch signal of the reference point. If the level of switch signal is detected correct after positioning, it means the work table has properly returned to the reference point. If incorrect, it means the there is too high tolerance of positioning, and the system will alarm: (1284 error of coordinate values of reference point or too high tolerance of machine tool's positioning.)
- 2) Before G27 instruction is executed, the machine tool must return to the reference point by manual operation after it is electrified. Otherwise, the system will alarm.
- 3) G27 is a non-mode instruction.
- 4) When only the address of a single axis is defined, the system will only detect the designated axis.
- 5) The tool offset value is effective when G27 is executed.

3.2.6 Return to mechanical origin (G28)

Instruction format: G28 X(U)_ Z(W)_;

Definition: Starts from the start point, fast moves to the middle point defined by X(U) and Z (W) and then returns to the mechanical origin. G28 is a non-mode instruction.

One of the instruction addresses X(U) and Z (W), or both of them, can be omitted, For details, see the table below.

Instruction	Definition
G28 X (U)_	Axis X returns to mechanical origin, and

	position of axis Z remains unchanged.
G28 Z (W)_	Axis Z returns to mechanical origin, and position of axis X remains unchanged.
G28	Positions of axis X and Z remain the unchanged and continue to execute the next program segment
G28 X (U) Z (W)	Axis X and Z return to mechanical origin simultaneously

X: Absolute coordinate of the middle point on axis X; U: Difference between the absolute coordinate of the middle point and the start point on axis X;

Z: Absolute coordinate of the middle point on axis Z; W: Difference between the absolute coordinate of the middle point and the start point on axis Z;

Actions under the instruction (see the figure below) :

- (1) The two axes separately move from the start point to the middle point in a quick-move mode (point A to point B).
- (2) After the two axes reach the middle point, they separately move from the middle point to their corresponding mechanical origin in a quick move mode (point B→point R).

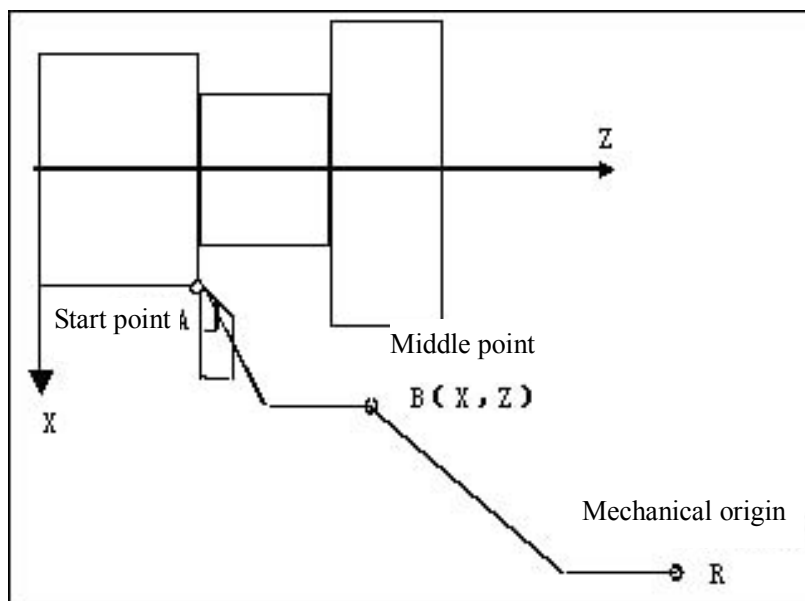

Note 1: After the system is electrified, if there is no manual operation for returning to the mechanical origin, the process that the axis moves from the middle point to the mechanical origin is the same as that the axis returns to the mechanical origin through manual operation (after the deceleration signal is received, the system decelerates to the mechanical mode).

Note 2: When the axis moves from A to B and from B to R, the two axes move separately and in a quick-move mode. Therefore, the locus may not be a straight line.

Note 3: When the machine tool is locked, if instruction G28 is executed, axis X and Z won't move, and the absolute coordinates of the system will be changed as that of the middle point, and then the system execute the next program segment. The indicator won't be illuminating.

Note 4: After instruction G28 is executed to allow the system to return to the mechanical origin, the system will cancel the tool length offset.

Note 5: If the machine tool is not equipped with a switch of origin, the operator should not allow the system to execute instruction G28. Otherwise, the machine tool may be damaged.

Note 6: If the start point of the machining program coincides with the reference point (mechanical origin), the system can execute G28 to return to the start point of the machining program.

Note 7: If the start point of the machining program doesn't coincide with the reference point (mechanical origin), the system can't execute G28 to return to the start point of the machining program, but it can do so by fast positioning or returning to the program's start point.

3.2.7 Return from the reference point (G29)

Instruction format:

Format: G29 X/U__ Z/W__

X/U: position of end point;

Z/W: position of end point.

Definition: It allows the instructed axis to move from the reference point through the middle point to the required position in a quick feed mode.

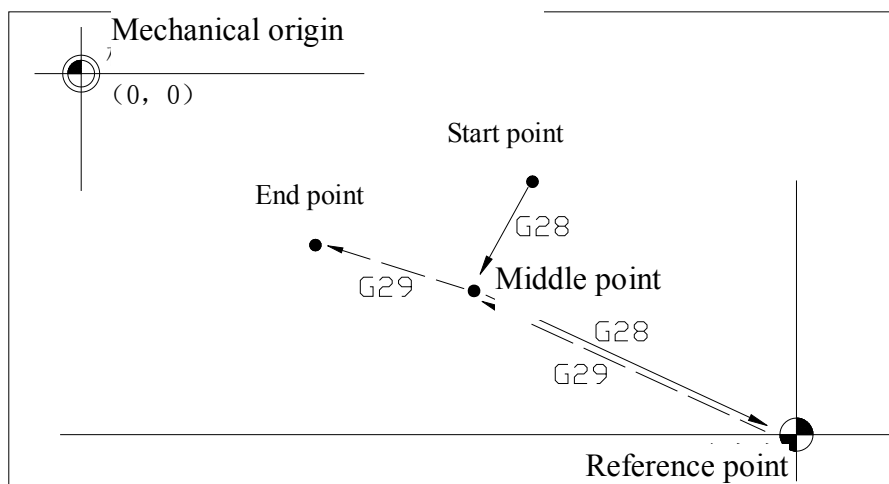

Note:

- 1) The position of the middle point is determined by the former G28 or G30.
- 2) G29 is normally executed after G28 or G30. When the instructed axis is located at the first reference point or the second reference point, if instruction G29 is executed without confirming the middle point, the system will alarm as "1291 position of middle point not defined."
- 3) When the end point is defined through the increment coordinate, the instruction value is equal to the distance from the middle point to the end point.
- 4) When only one axis is defined for returning, the undefined axis will default the original reference point as the coordinates of the end point.

3.2.8 Return to the 2nd reference point (G30)

Through instruction G30, the designated axis can return to the second reference point of the machine tool after fast positioned to the middle point.

Instruction format:

Format: G30 X/U__ Z/W__;

X/U: returning axis and position of middle point;

Z/W: returning axis and position of middle point.

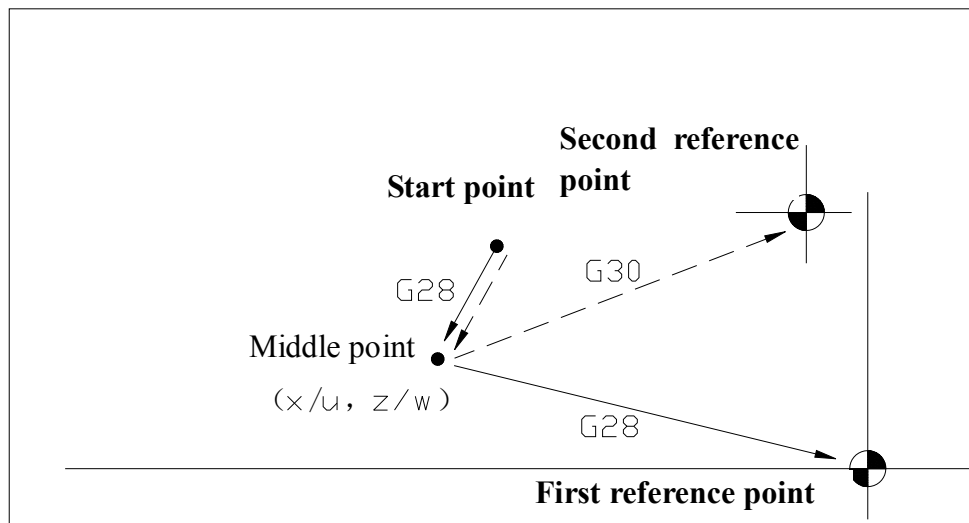

Note:

- 1) The second reference point is also the fixed point on the machine tool. The distance between it and the reference point of the machine tool is determined by the parameters.
- 2) If the default of the second reference point of axis X and Z of the machine coincides with its reference point, it can be set again if necessary (NO.16: coordinate X of the second reference point; NO.17: coordinate z of the second reference point).
- 3) After instruction G30 is executed and it is similar with G28, the operator can use instruction G29 to allow the designated axis to return from the second reference point.
- 4) After the system returns to the mechanical origin through the execution of G30, the system will cancel the tool length offset. However, the system will still execute the length offset at the middle point.
- 5) If the position of the middle point for G30 is not defined, the system will alarm (1292 G30 position of middle point not defined).
- 6) G30 serves as a non-mode instruction.

3.3 Thread cutting

3.3.1 Thread cutting (G32)

Instruction format: G32 X(U)__Z(W)__ F(I)__;

X(U): Coordinate value or increment of the end point to axis X

- for the thread
- Z(W): Coordinate value or increment of the end point to axis X for the thread
- F: Thread pitch (0.001~500 mm) in metric system, a displacement of the long axis achieved when the spindle rotates by one circle. After F instruction is executed, the situation will remain effective before another F instruction character defining the thread pitch is executed.
- I: Thread number per inch (0.06~25400threads/inch), a figure indicating the number of the threads for one inch of length on the long axis, and it can also be considered the circles the spindle rotates when the long axis moves by one inch. After I instruction is executed, the situation will remain effective. Each time the thread in British system is created, this instruction must be entered.

Definition: The locus of the tool is a straight line from the start point to the end point. When the system moves from the start point to the end point, the coordinate axis with the greater displacement (it is the radius in the case of axis X) is called the long axis, and the smaller the short axis. In the process of moving, the long axis will move by one pitch when the spindle rotates by one circle, and linear interpolation is engaged between the long and short axes, thus achieving machining with threads of equal pitch. F and I instructions will be used to define the pitch of threads in metric and British systems. With instruction G32M, the user can machine straight, tapered and end-surface threads with pitch in metric or British system.

When the coordinate value of start point is the same as that of end point on axis X (X or U not entered), the system will perform cutting for straight threads;

When the coordinate value of start point is the same as that of end point on axis Z (Z or W not entered), the system will perform cutting for end-surface threads;

When the coordinate value of start point and end points on both axis X and Z, the system will perform cutting for tapered threads. See Fig.3-7-1 below.

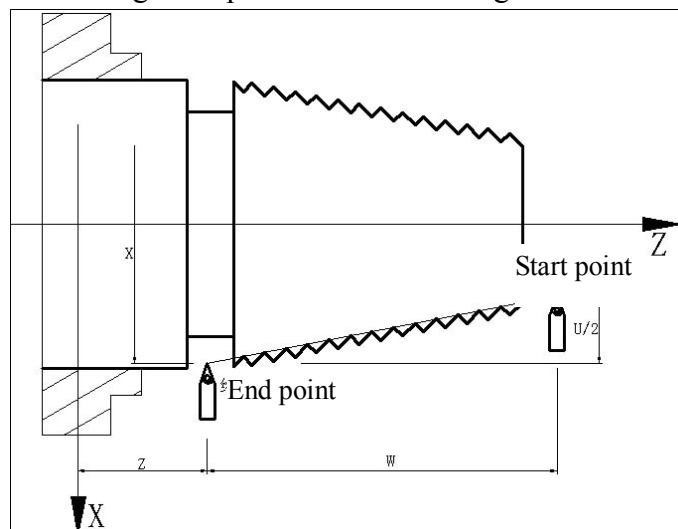

Fig.3-7-1

Thread pitch (0.001~500 mm) refers to the displacement of the long axis achieved when the spindle rotates by one circle (it is the radius in the case of axis X). The judgment of the long axis and short axis can be seen in Fig.3-7-2 below:

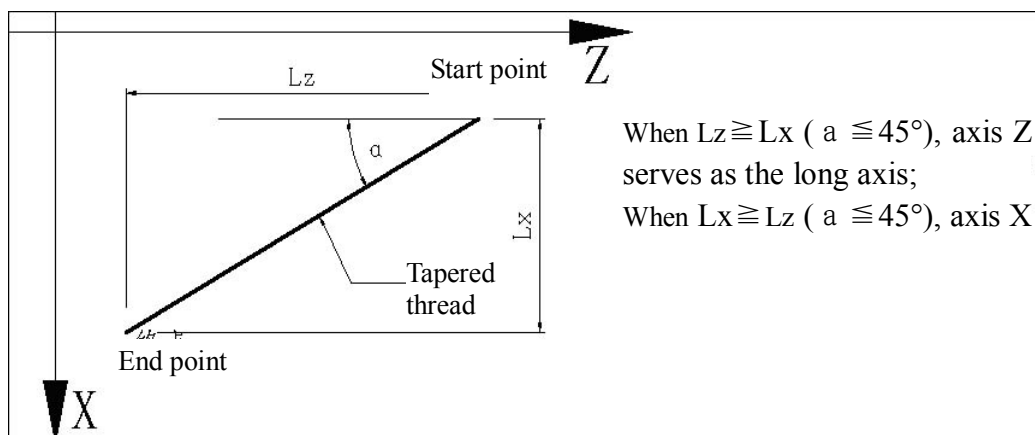

Fig. 3-7-2

- Precautions on thread cutting:
- Only when a spindle encoder is installed on it, can the machine tool perform thread cutting. The transmission ratio between the encoder and the spindle is 1:1. When the spindle encoder is used to produce the threads, the system will move axis X or Z to start the thread cutting only after it receives the signal of Z (origin) of the spindle encoder. Therefore, so long as the spindle speed does not change, the machining on the same threads can be performed through multiple cutting ways, such as rough cutting and fine cutting.
- As axis X and Z accelerates and decelerates at the beginning and end of the thread cutting, the thread size may have great errors. Therefore, a length $\delta 1$ should be introduced at the actual beginning of the thread and a length $\delta 2$ (normally the tool retract slot) at the actual end. In other words, the programmed thread length will be longer than the actual value, as shown in the figure below.

Example:

Thread pitch: 4mm. $\delta 1 = 3.5\text{mm}$, $\delta 2 = 3.5\text{mm}$, total cutting depth 1mm (single side), cut by two times.

```
G00 X28 Z3;      (cut by 0.5mm for the first time)
G32 X51 W-77 F4.0; (First cutting for the tapered thread)
G00 X55;        (Tool retract)
W77;           (Return to start point along axis Z)
X27;           (cut by 0.5mm for the second time)
G32 X50 W-77 F4.0; (Second cutting for the tapered thread)
G00 X55;        (Tool retract)
W77;           (Return to start point along axis Z)
```

Example:

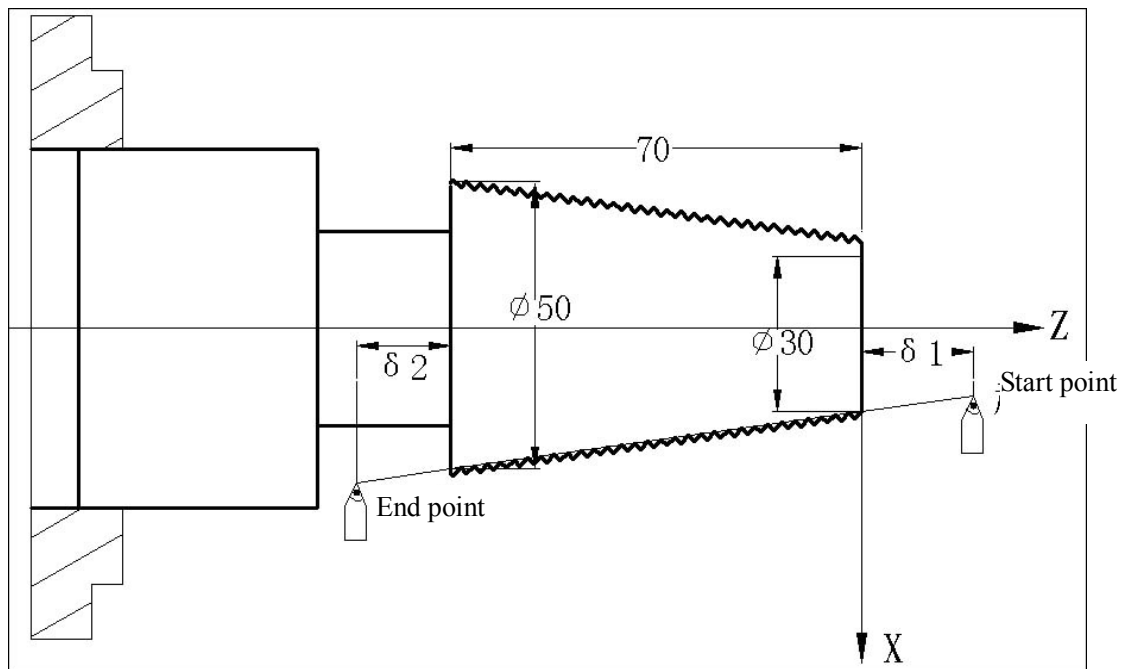

Fig. 3-7-3

- If the start point, end point and pitch in executing G32 is confirmed, the speed at which axis X and Z move at the time of thread cutting will be subject to the spindle's speed, but irrelevant to the speed magnification of the cutting feed. At the time of thread cutting, the control of spindle magnification will remain effective. When the spindle speed changes, do not regulate this speed while the system is cutting, nor stop the spindle (which may lead to damage to the tool and workpiece), for the acceleration and deceleration of axis X and Z will worsen the errors of pitch.
- At the time of thread cutting, the system won't respond when feed retaining is performed.
- Single program segment runs ineffective at the time of thread cutting.
- At the time of resetting, emergency stop or driver alarm, the process of thread cutting will stop immediately.

3.3.2 Axis Z's tapping cycle (G33)

Instruction format: G33 Z(W)___ F(I)___;

Definition: The tool's motion locus extends from the start point to end point, and from end point to start point again. In the movement, axis moves by one pitch each time the spindle rotates by one circle, keeping consistent with the pitch of the tap. Inside the hole of the workpiece is a spiral slot formed, and the thread cutting can be completed by one time.

Note: G33 serves as mode G instruction;

Z (W): When Z or W is not entered, the coordinate value of start point is the same as that of the end point on axis Z, and no cutting proceeds.

F: Refers to the thread pitch in metric system, with a range 0.001~500 mm;

I: Number of threads per inch, with a range 0.06~25400 thread/inch

Details of the cycle:

- (1) Tool advances along axis Z to tap the thread (spindle must be defined as “ON” before G33 is executed);
- (2) Once the tool reaches the end point of axis Z as programmed, the M05 signal will be output;
- (3) The tool stops after the spindle is detected;
- (4) Signal of spindle’s reverse rotation is output (which is opposite to the former rotation direction of the spindle)’
- (5) Tool retracts to start point along axis Z;
- (6) Spindle resumes the rotation speed reached before G32 is executed.

Program:

```
O0011;  
G00 Z90 X0Z0 M03; start spindle  
G33 -Z50 F1.5; tapping cycle  
G00 X60 Z10; keep machining  
M30
```

Note 1: The rotation direction of the spindle should be determined in light of the rotation speed of the tap. After tapping, the spindle will resume the former rotation direction.

Note 2: This instruction is used for hard tapping. When the signal to stop the spindle becomes effective, the spindle will decelerate for some time before it stops. During this time, axis Z will advance with the rotation of the spindle before the spindle stops completely. Therefore, at the time of thread cutting, the bottom hole of the thread should be slightly deeper than what is actually desired, whose extra length should be subject to the spindle’s speed and the brake for the spindle at the time of thread cutting.

Note 3: At the time of thread cutting, the speed of axis Z is determined by the spindle’s speed and the thread pitch, but irrelevant to the speed magnification of cutting feed.

Note 4: At the time of running a single program segment or retaining advancement, the system will display “pause”. The tapping cycle won’t stop until the tool returns to the start point after tapping.

Note 5: At the time of resetting, emergency stop or driver alarm, the process of tapping will accelerate to stop.

3.4 Setting workpiece's coordinates (G50)

Instruction format: G50 X(U) Z(W);

X: New absolute coordinate of the current position on axis X;

U: Difference between the new absolute

coordinate of the current position on axis X and the absolute coordinate before the execution of the instruction.

Z: New absolute coordinate of the current position on axis Z.

W: Difference between the new absolute coordinate of the current position on axis Z and the absolute coordinate before the execution of the instruction.

Definition: To set the absolute coordinates of the current position to establish a coordinate system (also called floating coordinate system) of the workpiece in the system. Once this instruction is executed, the system will set the current position as the program origin, to which the tool will return after program resetting is performed. After the workpiece's coordinate system is established, the values for the programming of absolute coordinates will be entered on the basis of this system before G50 is executed again to establish a new coordinate system. G50 serves as a non-mode G instruction.

In executing G50, if X (U) or Z(W) is not entered, they will be set as the former absolute coordinates of the current position. If both of them are not entered, the current coordinate value will remain unchanged. So long as G50 is executed, the system will consider the current position the program origin.

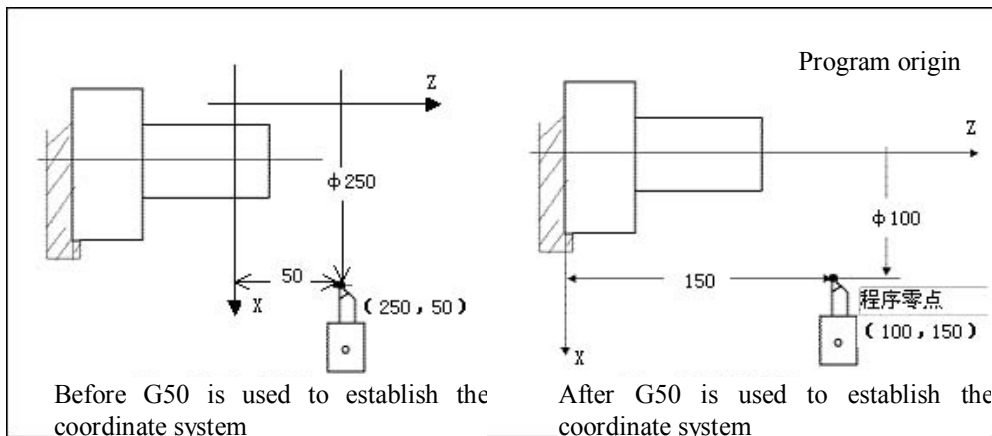

As shown in the above figure, after the instruction segment “G50 X100 Z150” is executed, the workpiece's coordinate system will be established and the point X100,Z150) considered the program origin.

Note: In the state of tool length offset, if G50 is executed to establish the coordinate system, the absolute coordinates shown in the system are set values modified in accordance with the current tool deviation, while the program origin represents the position determined by G50 in the workpiece's coordinate system. When the tool returns to program origin in this state, the end of resetting is the position of program origin after the tool length offset is canceled.

. Example:

Current tool offset state	Displayed coordinates after G50 X20 Z20 is executed	Tool offset value 01
T0100	X:20 Z:20	X:12

T0101	X:32	Z:43	Z:23
-------	------	------	------

3.5 Fixed cycle

To simplify the programming, this system provides a G instruction with which the single-time machining cycle, including fast positioning, linear/thread cutting and fast returning to start point, can be completed by only one program segment.

- G90: Axial cutting cycle
- G94: Radial cutting cycle
- G92: Thread cutting cycle

3.5.1 Axial cutting cycle (G90)

Format: G90 X/U__ Z/W__ R__ F__;

Instruction format: G94 X/U__ Z/W__ R__ F;

- X/U: Coordinate of end point for cutting on axis X;
- Z/W: Coordinate of end point for cutting on axis Z;

F: Cutting speed

R: Conic surface's inclination. This refers to the difference between the radial coordinate of the start point for cutting and that of end point (radius). When R is inconsistent with U, it should be as $|R| \leq |U/2|$. If R is not defined, the system will be engaged in the machining for a surface of a column, as shown the figure below:

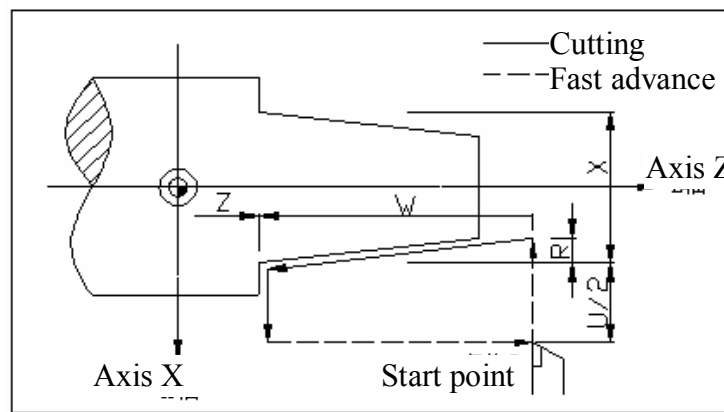
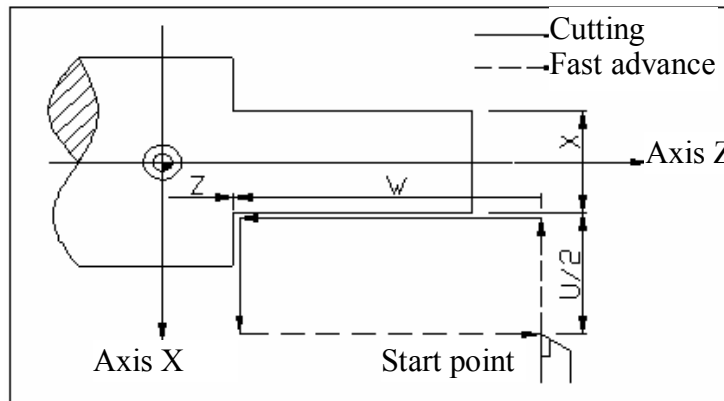

Execution process:

- 1) Axis X fast positions from start point to the start point of cutting (G0);
- 2) Linear interpolation (G1) from start point of cutting to end point;
- 3) The radial coordinates by which axis X retracts to start point of the cycle in an interpolation way (G1);
- 4) Axis Z in fast positioning (G0) returns to start point and the cycle ends.

Note:

- 1) G90 serves as a mode instruction;
- 2) In single segment operation, the system will stop at the end point of each program segment, and pause state and operation resumption become effective in the motion.
- 3) U, W and R show the relative positions of the end point and start point of cutting. Four combined loci are available for G90 depending on the symbols.

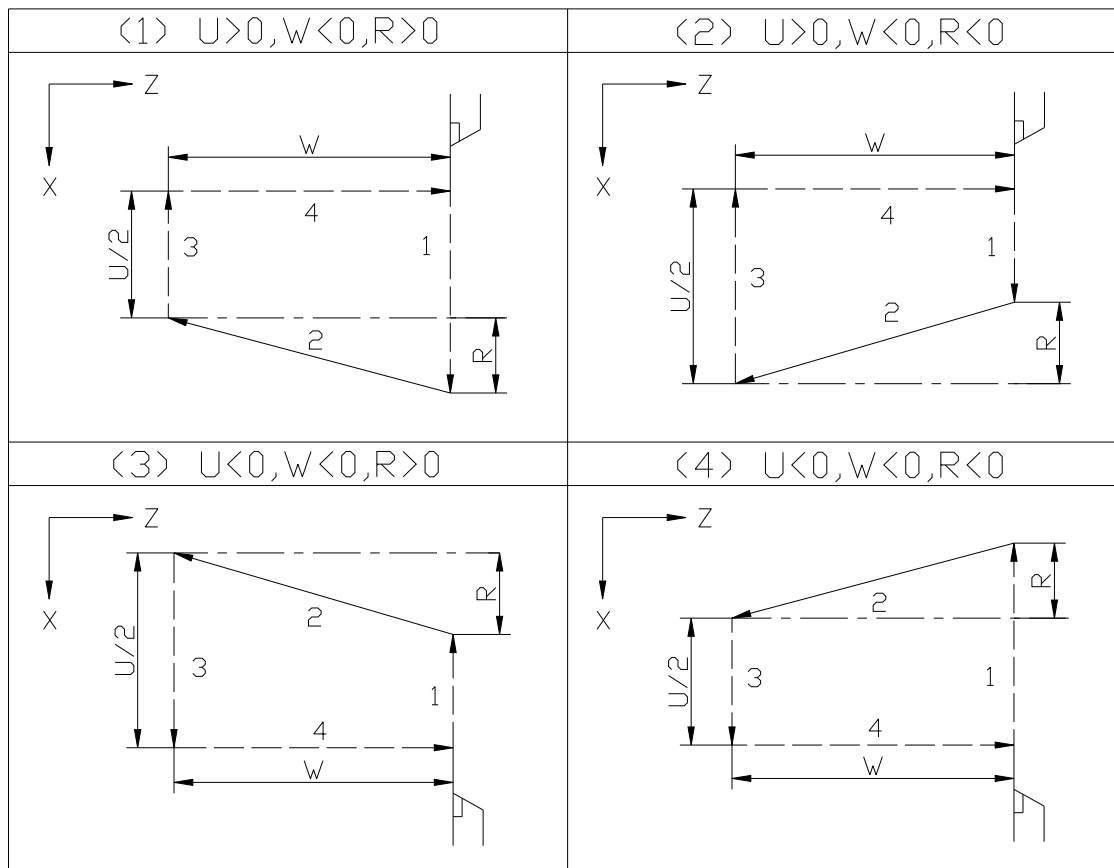

When symbols of R and U are inconsistent with each other, if $|R| > |U/2|$, the system will alarm as “1268-G90, G92 and G94 program error”, meaning R value has exceeded the permitted range.

- 4) At the time of first cutting, if U is 0, the system will default the current value as the coordinates of the end point. W can't be 0. Otherwise, the system will alarm (1281- G90G92 coordinate on axis Z not defined);
- 5) Before the execution of G90, the operator should define the position of start point. Otherwise, the system will take the current point as the start point.
- 6) In MDI mode, G90 is effective. And it also performs the function of mode instruction.

See the example in Fig. 3-10-4:

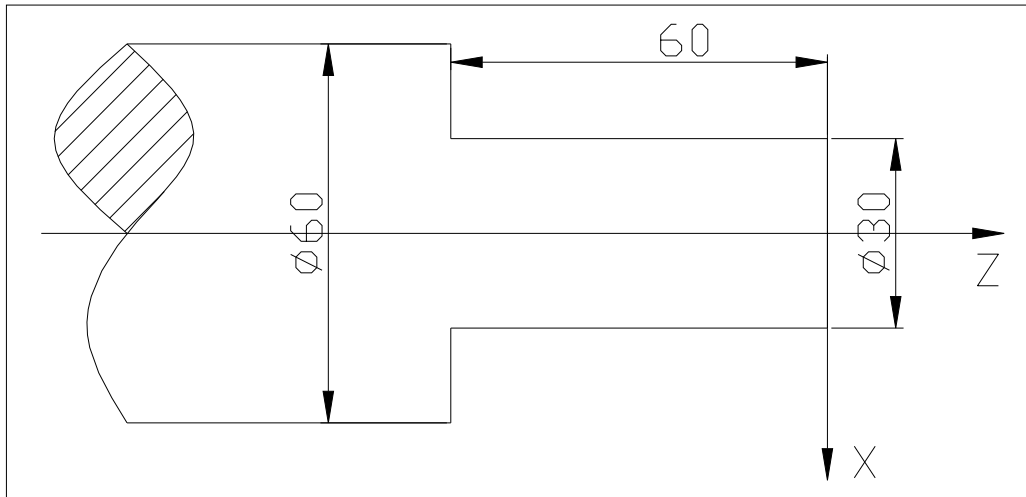

Fig:3-10-4

```

O9001
M03 S500T0101
G00 X70 Z2
G90X56Z-60F500
X52
X48
X44
X40
X36
X32
X30
M30

```

3.5.2 Thread cutting cycle (G92)

Instruction format: G92 X/U__ Z/W__ R__ F/I__ J_ K_ L_ Q_;

X/U: Coordinate of the thread's end point on axis X;

Z/W: Coordinate of the thread's end point on axis Z;

F: Thread pitch;

I: Thread pitch in British system;

R: Thread's inclination. This refers to the difference between the radial coordinate of the start point for cutting and that of end point (radius). When R is inconsistent with U, it should be as $|R| \leq |U/2|$. If R is not defined, the system will be engaged in the machining for straight thread.

J: Speed ratio of tail return on axis X;

K: Speed ratio of thread cutting return on axis Z;

L: Number of multiple thread heads, with range 1-100;

Q: Deviation of the start point, with range 0-360°.

tail return.

- 4) L_ multi-head thread cutting function. L function will remain effective before the mode function of the current thread instruction is canceled. The struction G92 without defined L defaults as single-head thread. (If both F and I are defined in the same program segment, the system will alarm as 276—thread pitch instruction repeated.)
- 5) In thread cutting, the magnification for feed speed becomes ineffective.
- 6) Q (deviation of thread’s start point) can be effective only in the current program segment. In machining, after the angle defined by Q is deviated, the system will machine the thread. If Q is not defined or is defined over or equal to 360°.
- 7) U, W and R show the relative positions of the end point and start point of cutting. Four combined loci are available depending on the symbols.

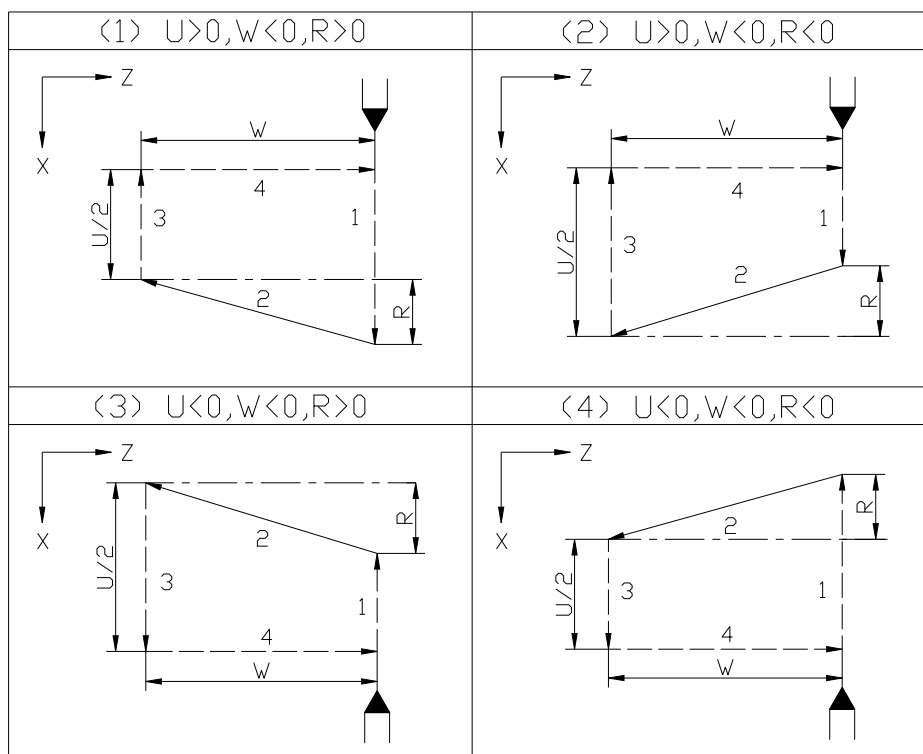

When symbols of R and U are inconsistent with each other, if $|R| > |U/2|$, the system will alarm as “1268-G90, G92 and G94 program error”, meaning R value has exceeded the permitted range.

- 8) In MDI mode, the system can’t execute instruction G92;
- 9) At the time of first cutting, if U is 0, the system will default the current value as the coordinates of the end point. W can’t be 0. Otherwise, the system will alarm (1281- G90G92 coordinate on axis Z not defined);
- 10) In thread cutting, the control of spindle’s magnification is ineffective.
- 11) With the control of linear speed, the instruction for thread cutting is ineffective.
- 12) The system will calculate the feed speed per minute. If the maximum advance speed is exceeded, the system will alarm (1275—feed speed for thread cutting exceeds the max. value).
- 13) The spindle’s speed is limited as follows:

$$1 \leq R \leq \frac{\text{Max. advance speed}}{\text{Thread pitch}} ; \text{ and } R \leq \text{permitted rotation speed of encoder (r/min).}$$

R: Spindle’s speed (r/min);
Lead of thread: mm or inch;

Max. feed speed: mm/min and inch/min (subject to mechanical specification);

14) The tail-return function of G92 can help machine threads without retract slot. However, a lead-in length of the thread must be left in front of the actual start point.

15) Under instruction G92, the tool can advance for multiple times to complete the machining of the thread. However, it can't accomplish the machining of two consecutive threads, nor can it machine the end-surface. The definition of G92 on thread pitch is the same as G32, which refers to the displacement obtained when the spindle rotates by one circle (it is the radius in the case of axis X).

Precautions on thread cutting under G92:

- Only when a spindle encoder is installed on it, can the machine tool perform thread cutting. The transmission ratio between the encoder and the spindle is 1:1. The encoder of the spindle can output A/B differential signal with 90° phase difference and Z signal (transferred signal). When the spindle encoder is used to produce the threads, the system will move axis X or Z to start the thread cutting only after it receives the signal of Z (origin) of the spindle encoder. Therefore, so long as the spindle speed does not change, the machining on the same threads can be performed through multiple G92 program segments and multiple cutting ways, such as rough cutting and fine cutting.
- As axis X and Z accelerates and decelerates at the beginning and end of the thread cutting, the thread size may have great errors. The tail-return function of G92 can help machine threads without retract slot. However, a lead-in length of the thread must be left in front of the actual start point.
- If the start point, end point and pitch in executing G32 is confirmed, the speed at which axis X and Z move at the time of thread cutting will be subject to the spindle's speed, but irrelevant to the speed magnification of the cutting feed. At the time of thread cutting, the control of spindle magnification will remain effective. When the spindle speed changes, do not regulate this speed while the system is cutting, nor stop the spindle (which may lead to damage to the tool and workpiece), for the acceleration and deceleration of axis X and Z will worsen the errors of pitch.
- At the time of thread cutting, the system won't respond when feed retaining is performed.
- Single program segment runs ineffective at the time of thread cutting. The system will pause after the first non-cutting action in the thread-creation cycle is completed. At the time of resetting, emergency stop or driver alarm, the process of thread cutting will stop immediately.

See the example in Fig. 3-10-7:

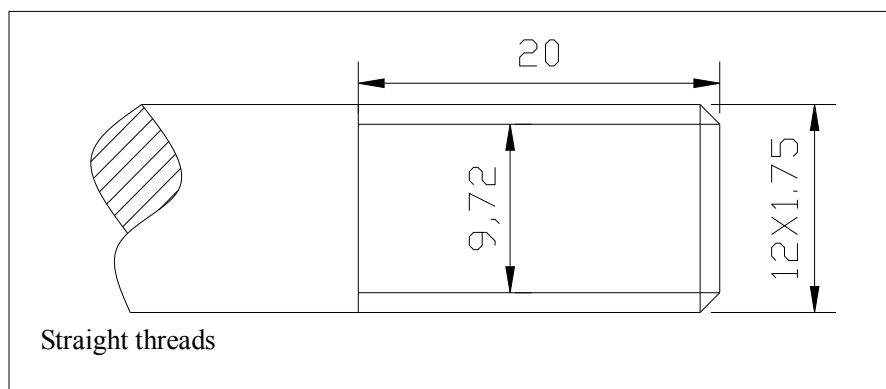

Fig. 3-10-7

Program:O3201
 M03S500
 G00X9.72Z2;
 G32W-20 F1.75
 G00X20
 Z20
 M30

3.5.3 Radial cutting cycle (G94)

Instruction format: G94 X/U Z/W R_ F;

X/U: Coordinate of end point for cutting on axis X;

Z/W: Coordinate of end point for cutting on axis X;

F: Cutting speed

R: R: Conic surface's inclination. This refers to the difference between the radial coordinate of the start point for cutting and that of end point. When R is inconsistent with W, it should be as $|R| \leq |W|$. If R is not defined, the system will be engaged in the machining for a straight end surface, as shown the figure below:

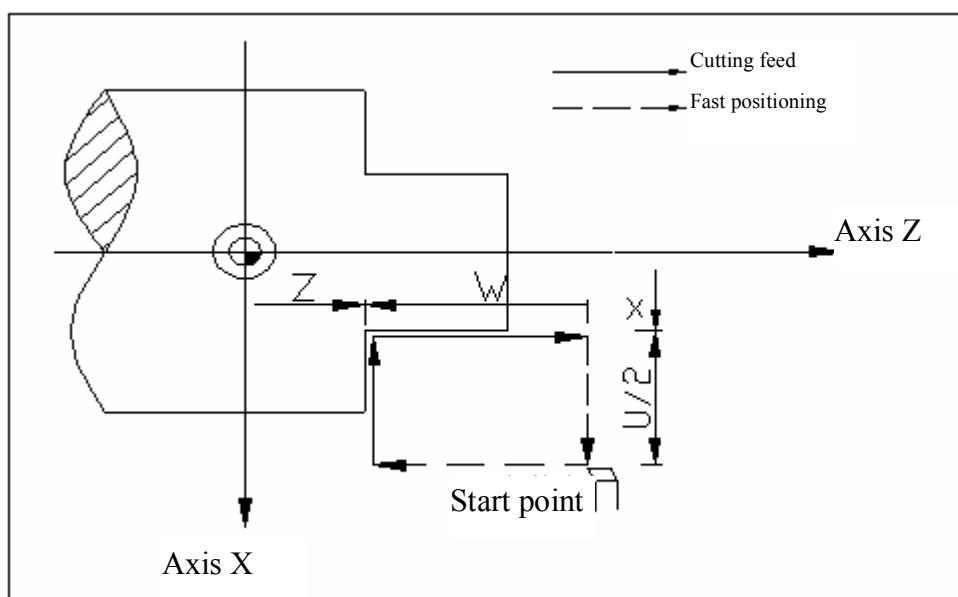

Execution process:

- 5) Axis X fast positions from start point to the start point of cutting (G0);
- 6) Linear interpolation (G1) from start point of cutting to end point;
- 7) The axial coordinates by which axis Z retracts to start point of the cycle in an interpolation way (G1);
- 8) Axis Z in fast positioning (G0) returns to start point and the cycle ends.

Note:

- 7) G94 serves as a mode instruction;
- 8) In single segment operation, the system will stop at the end point of each program segment, and pause state and operation resumption become effective in the motion.
- 9) U, W and R show the relative positions of the end point and start point of cutting. Four combined loci are available for G94 depending on the symbols.

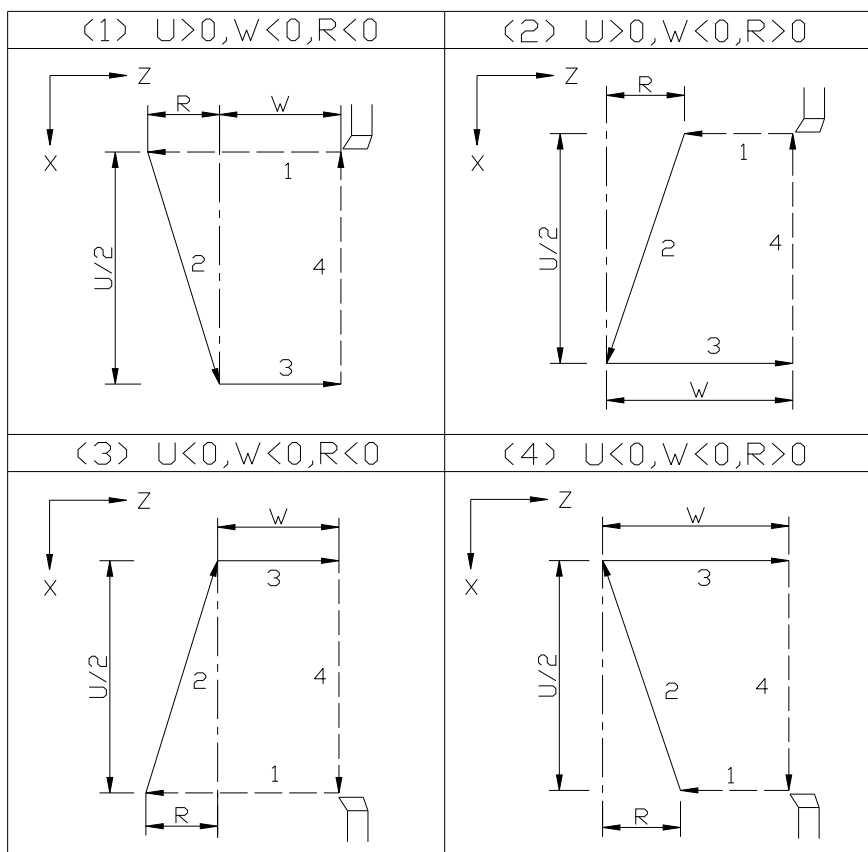

When symbols of R and W are inconsistent with each other, if $|R| > |W|$, the system will alarm as “1268-G90, G92 and G94 program error”, meaning R value has exceeded the permitted range.

- 10) At the time of first cutting, if W is 0, the system will default the current value as the coordinates of the end point. W can't be 0. Otherwise, the system will alarm (1240- G94 coordinate on axis X not defined);
- 11) Before the execution of G94, the operator should define the position of start point. Otherwise, the system will take the current point as the start point.
- 12) In MDI mode, G94 is effective. And it also performs the function of mode instruction.

3.5.4 Precautions on fixed cycle instruction

1) In fixed cycle instructions, once X(U) Z(W) R is executed, the instruction value of X(U) Z(W) R will remain effective before a new fixed instruction is executed to define X(U) Z(W) R again. If G00, G01, G02, G03 and G32 are executed, the instruction for retaining R will be deleted.

2) When the program segment next to G90, G92 or G94 program segment is of instruction characters that do not cause motion, if this segment is executed, the action of G90, G92 or G94 program segment will be performed again. To avoid such a situation, you must use other G instructions to cancel the cyclic operation after the fixed cycle.

(For example)

```
M3; (start the spindle)
G90 X200.0 Z10.0 F2000;
X205.0(repeat the execution of G90 once)
X206.0 Z20.0(repeat the execution of G90 once)
```

3) If the fixed cycle instruction shares the segment with M, S and T instructions, the fixed cycle instruction can be executed simultaneously with them. But if the fixed cycle (because of G00 and G01) is canceled after M, S and T instructions, the fixed cycle instruction must be executed again, like the example below:

(Example)

```
N003 T0101;
N010 G90 X20.0 Z10.0 F2000;
N011 G00 T0202;
N012 G90 X20.5 Z10.0;
```

3.6 Multi-cycle instructions

G code	Definition	Format
G70	Fine machining cycle G70	G70 P(ns) Q(nf);
G71	Axial rough machining cycle G71	G71 U(Δd) R(e) F__ S__ T__ ; G71 P(ns) Q(nf) U(Δu) W(Δw);
G72	Radial rough machining cycle G72	G72 W(Δd) R(e) F__ S__ T__ ; G72 P(ns) Q(nf) U(Δu) W(Δw);
G73	Enclosed cutting cycle G73	G73 U(Δi) W(Δk) R(d) F__ S__ T__ ; G73 P(ns) Q(nf) U(Δu) W(Δw) ;
G74	Axial slot-cutting multiple cycles G74	G74 R(e) ; G74 X(U)_ Z(W)_ P(Δi)Q(Δk) R(Δd) F__ ;

G75	Radial slot-cutting multiple cycles G75	G75 R(<u>e</u>) ; G75 X(U)_ Z(W)_ P(<u>Δi</u>) Q(<u>Δk</u>) R(<u>Δd</u>) F_ ;
G76	Multiple thread-cutting cycles G76	G76 P(<u>m</u>)(<u>r</u>)(<u>a</u>) Q(<u>Δdmin</u>) R(<u>d</u>): G76 X(U)_ Z(W)_ R(<u>i</u>) P(<u>k</u>) Q(<u>Δd</u>) F(<u>l</u>) ;

3.6.1 Axial rough cutting cycle (G71)

Instruction format:

Format: G71 U(Δd) R(e) F_ S_ T_

G71 P(ns) Q(nf) U(Δu) W(Δw)

U(Δd): Single-time feed (radius value) in rough machining on axis X, without symbol;

R (e): Single-time retract (radius value) in rough machining on axis X, without symbol;

P (ns): Line number of start program segment for fine-machining locus;

Q(nf): Line number of end program segment for fine-machining locus;

U(Δu): Reserve for fine-machining on axis X, without symbol;

W(Δw): Reserve for fine-machining on axis Z, without symbol;

F: Feed speed in rough machining

S: Spindle speed in rough machining

T: Tool number, tool offset number

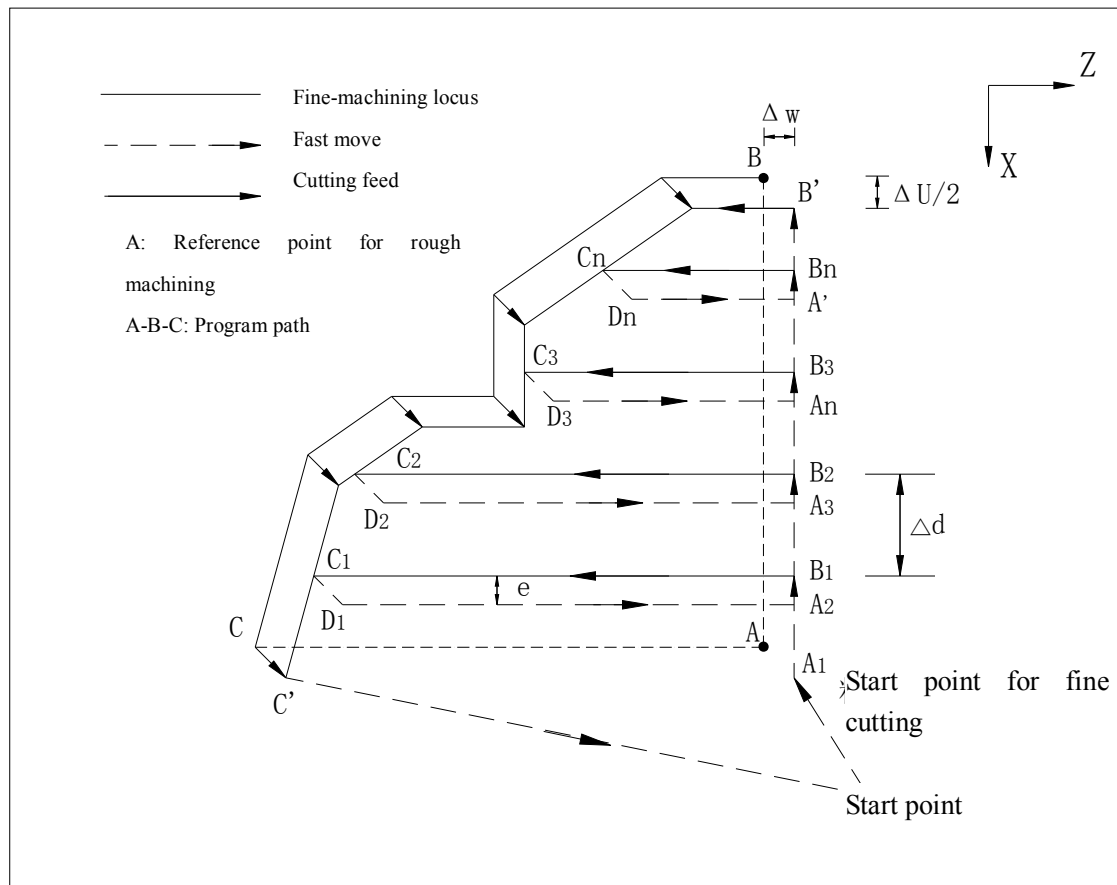

Execution process:

(1) Start point→A1: fast move;

(2) The first rough machining cycle: A1→B1→C1→D1→A2

A1→B1, C1→D1→A2: fast move

B1→C1: linear interpolation

(3) The second rough machining cycle: A2→B2→C2→D2→A3

A2→B2, C2→D2→A3: fast move

B2→C2: linear interpolation

(4) The Nth rough machining cycle: An→Bn→Cn→Dn→A'

An→Bn, Cn→Dn→A': fast move

Bn→Cn: linear interpolation

(5) The last rough machining cycle: A'→B'→C'→start point

A'→B': fast move

B'→C': Interpolation mode is defined by program segment ns→nf. The interpolation speed is subject to F value defined by G71 program segment. If not defined, the default F value will be used.

C'→Start point: fast move. G71 rough machining cycle ends.

Note:

- 1) Program segment must be compiled after G71 program segment. The system won't execute the program segment between G71 and ns→nf.
- 2) The F value in G71 program segment is effective when G71 rough machining cycle is executed. If F value is not defined in G71 program segment, the default F value will be used. The program segment ns-nf is effective only when G70 is executed.
- 3) At the time of execution in single-segment state, one rough-machining cycle (advance→cut→retract→return) serves as one single segment.
- 4) In movement, pause and resetting are effective.
- 5) When a compound instruction is used for multiple times in the same program segment, it is not allowed that a program segment number be used repeatedly in

- ns~nf. Otherwise, the system may wrongly run ns~nf profile when the next compound instruction is executed.
- 6) If the feed of the last time is less than $U(\Delta d)$, the system will directly perform the rough-machining cycle for the last time.
 - 7) Retract path: After the rough cutting for the last time is completed, the tool retracts from point nf the start point.
 - 8) Before the execution of G71, the start point of the tool must be defined. It must be at the outer side of the limit of the program path. Otherwise, the system will alarm (1277—G71, G72 and G73, error of start point). If the start point is not defined, the current point will be considered the start point.
 - 9) To define the outer side of the program path, see the figure below.

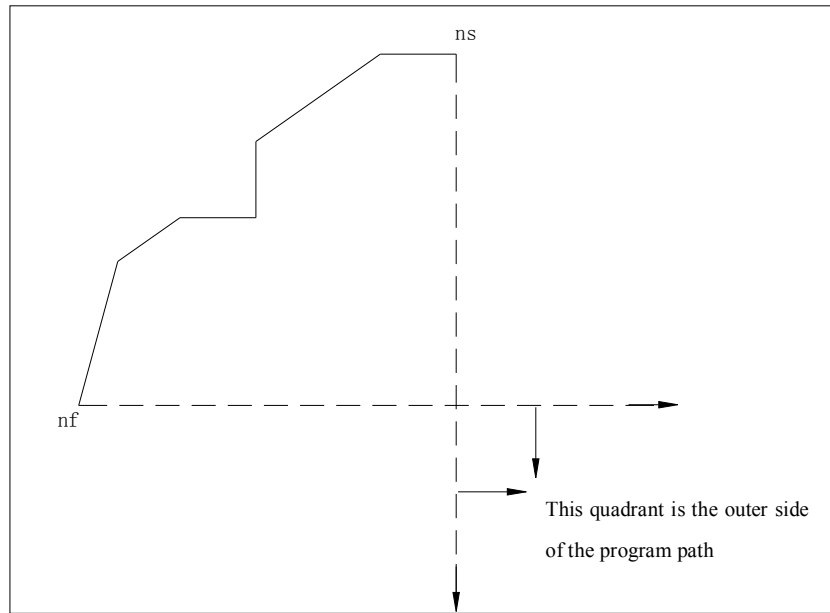

- 10) The deviation direction of rough-machining is determined by the program path: (As shown in the figure below, the program path of machining is A→B→C).

Prerequisite for Judgment	Treatment
Value of C (nf program segment) on axis X > Value of B (ns program segment) on axis X; Value of C on axis Z > Value of B on axis Z	①
Value of C (nf program segment) on axis X > Value of B (ns program segment) on axis X; Value of C on axis Z < Value of B on axis Z	②
Value of C (nf program segment) on axis X < Value of B (ns program segment) on axis X; Value of C on axis Z > Value of B on axis Z	③
Value of C (nf program segment) on axis X < Value of B (ns program segment) on axis X; Value of C on axis Z < Value of B on axis Z	④
Value of C (nf program segment) on axis X = Value of B (ns program segment) on axis X, or Value of B (nf program segment) on axis Z = Value of B (ns program segment) on axis Z	Send out alarm of error: 1232

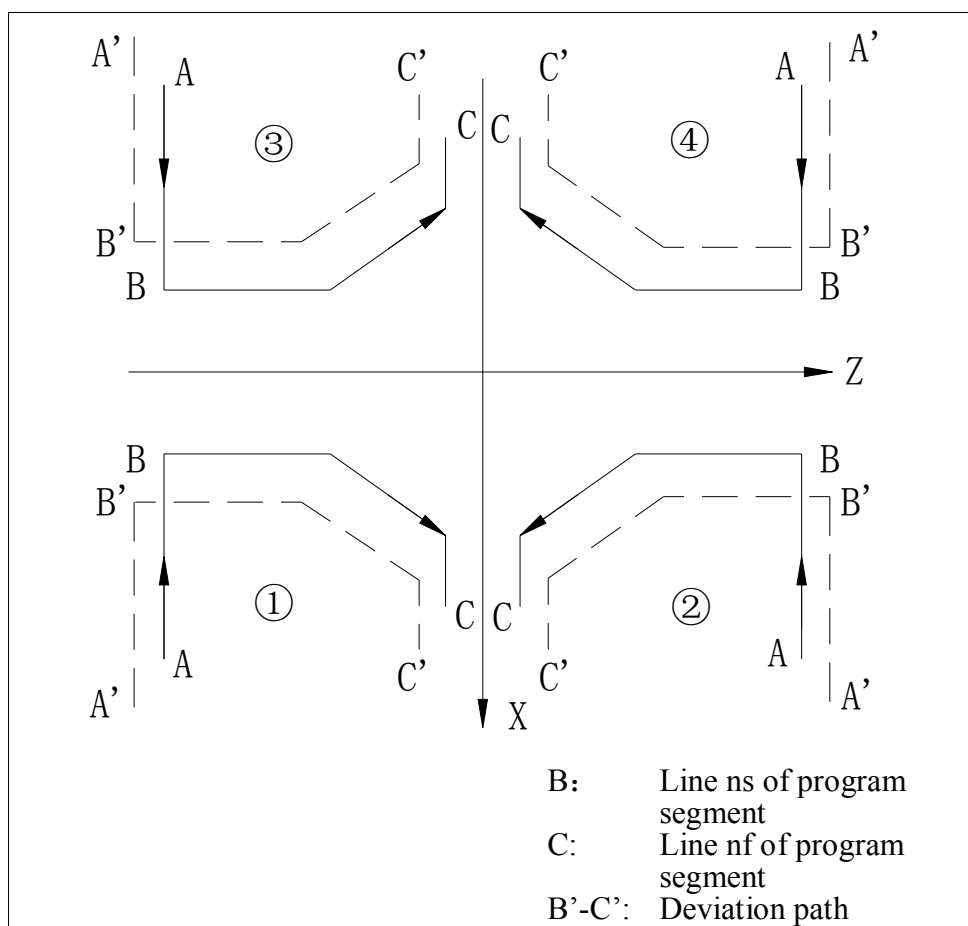

Related parameters and precautions:

- 1) Δd can be set through the parameter (100-G71 feed of rough-machining cycle), and the set value can be modified through the program instruction. When Δd is 0 or higher than the total cutting output, the system will alarm. E can be set through the parameter (101- G71 cycle retract), and the set value can be modified through the program instruction. The retract angle is 45° . When R (e) is zero, no retracting will be performed.
- 2) Δu can be set through the parameter (102-G71 reserve for fine machining on axis X), and the set value can be modified through the program instruction. When Δu is 0, no reserve will be left for machining on axis X. When Δu is higher than Δd , the system will alarm, for the end point of the first rough machining can't be computed.
- 3) Δw can be set through the parameter (103-G71 reserve for fine machining on axis Z), and the set value can be modified through the program instruction. When Δw is 0, no reserve will be left for machining on axis zX.
- 4) In program segment ns-nf, the size of axis X and Z must change in a single way (continuous increase or continuous decrease). Otherwise, the system will alarm
- 9) The program segment ns-nf can only include the following G instructions: G00, G01, G02, G03 and G04, but not the following M instructions: M00, M30, M98 and M99. Otherwise, the system will alarm.
- 10) Program segment Ns can only be G00 and G01. Otherwise, the system will alarm (1225-start program segment G71, G72 or G73 includes G code that is not supported).

Example of programmed machining with G71:

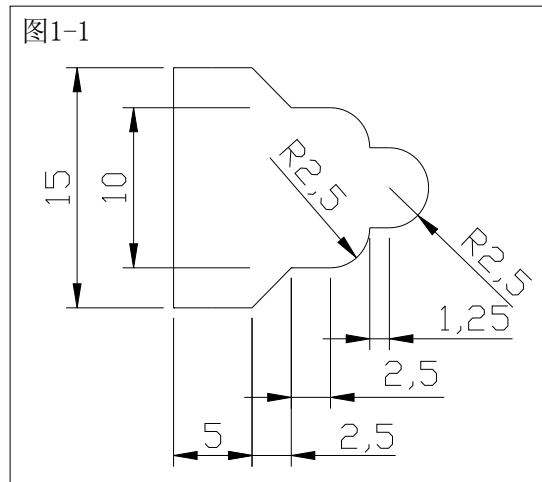

Fig. 3-11-3

```

O7101
M03 S500T0101
G00 X25Z10
M03S550F3000
G71U0.5R0.5
G71P10Q20U0.2W0.2
N10G0X0Z0F300
G2X5Z-2.5R2.5F200
G1W-1.25F300
G2X10W-2.5R2.5F200
G1W-2.5F300
N20X15W-2.5
G70P10Q20
G0X20
Z0
M30
%
```

3.6.2 Radial rough cutting cycle (G72)

Instruction format: G72 W(Δ d) R(e) F_ S_ T_

G72 P(ns) Q(nf) U(Δ u) W(Δ w)

W(Δ d): Single-time feed (radius value) in rough machining on axis X (without symbol, unit: mm);

R(e): Single-time retract (radius value) in rough machining on axis X (without symbol, unit: mm);

P(ns): Line number of start program segment for fine-machining locus;

Q(nf): Line number of end program segment for fine-machining locus;

U(Δu): Reserve for fine-machining on axis X, without symbol;

W(Δw): Reserve for fine-machining on axis Z, without symbol,

F: Feed speed in rough machining

S: Spindle speed in rough machining

T: Tool number, tool offset number

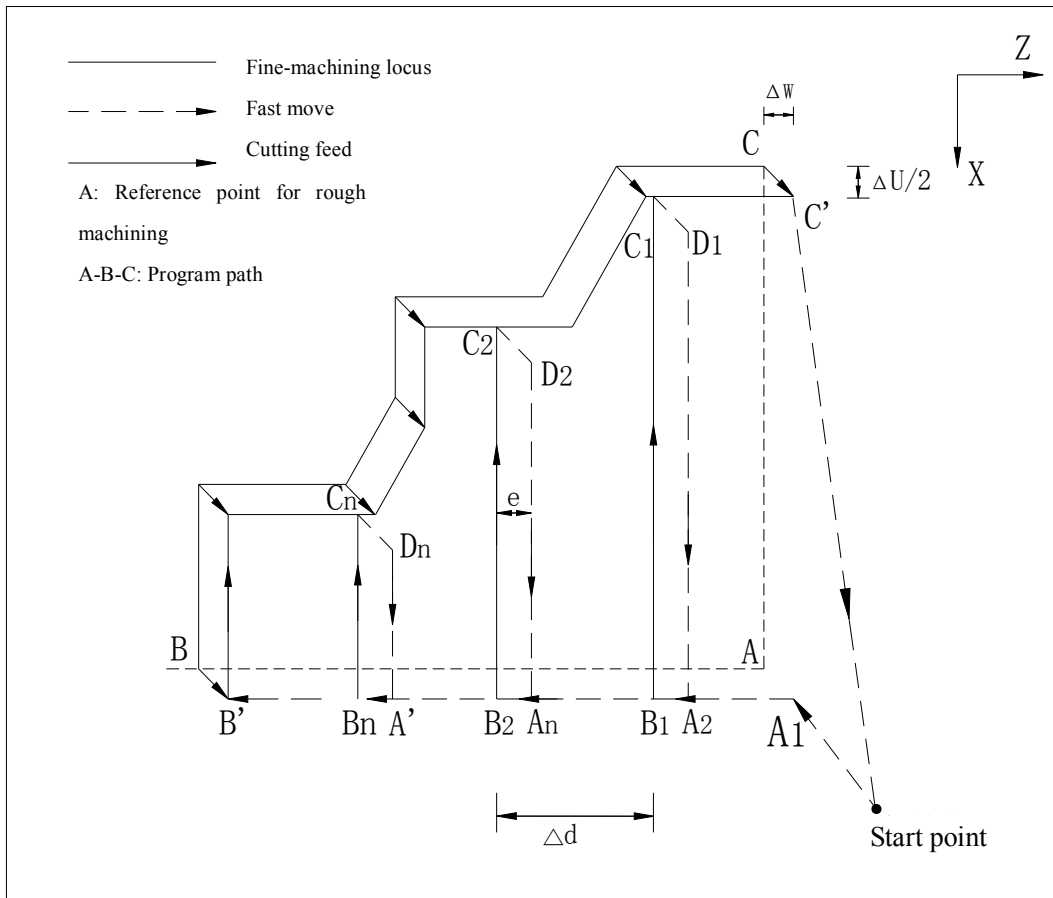

Execution process:

- (1) Start point→A1: fast move;
- (2) The first rough machining cycle: A1→B1→C1→D1→A2
A1→B1, C1→D1→A2: fast move
B1→C1: linear interpolation
- (3) The second rough machining cycle: A2→B2→C2→D2→A3
A2→B2, C2→D2→A3: fast move
B2→C2: linear interpolation
- (4) The Nth rough machining cycle: An→Bn→Cn→Dn→A'
An→Bn, Cn→Dn→A': fast move
Bn→Cn: linear interpolation
- (5) The last rough machining cycle: A'→B'→C'→start point

segment) on axis X; Value of C on axis Z < Value of B on axis Z	
Value of C (nf program segment) on axis X < Value of B (ns program segment) on axis X; Value of C on axis Z > Value of B on axis Z	②
Value of C (nf program segment) on axis X < Value of B (ns program segment) on axis X; Value of C on axis Z < Value of B on axis Z	①
Value of C (nf program segment) on axis X = Value of B (ns program segment) on axis X, or Value of B (nf program segment) on axis Z = Value of B (ns program segment) on axis Z	Send out alarm of error: 1232

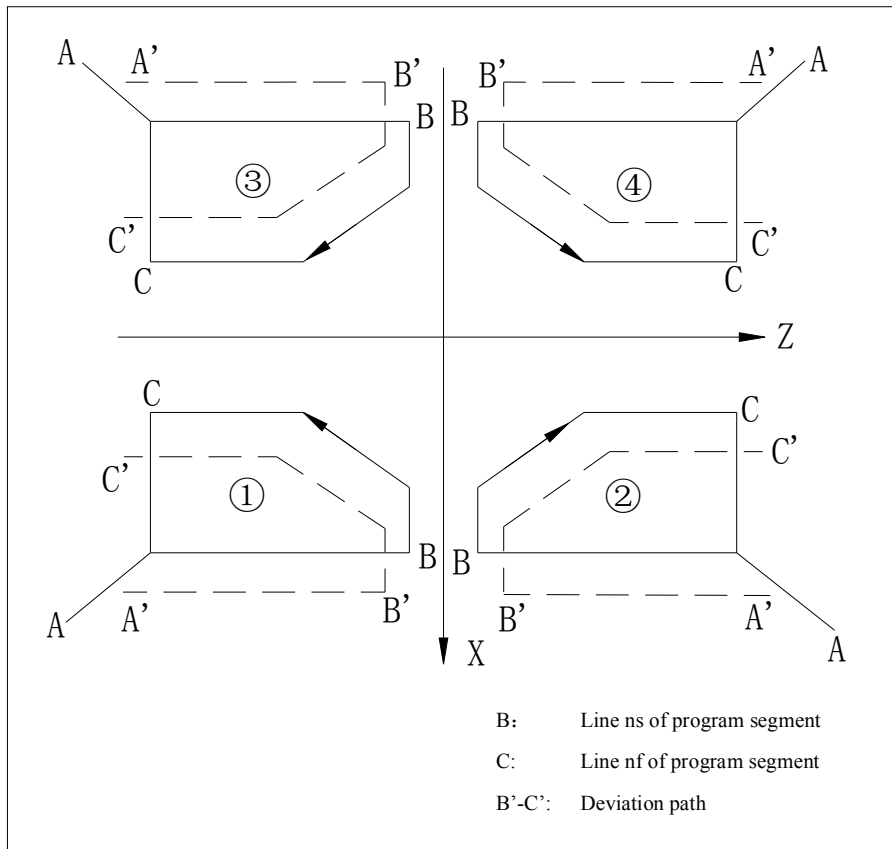

1) Δd can be set through the parameter (100-G72 feed of rough-machining cycle), and the set value can be modified through the program instruction. When Δd is 0 or higher than the total cutting output, the system will alarm.

2) E can be set through the parameter (113- G72 cycle retract for rough machining), and the set value can be modified through the program instruction. The retract angle is 45° . When $R(e)$ is zero, no retracting will be performed.

3) Δu can be set through the parameter (114-G72 reserve for fine machining on axis X), and the set value can be modified through the program instruction. When Δu is 0, no reserve will be left for machining on axis X.

4) Δw can be set through the parameter (115-G72 reserve for fine machining on axis Z), and the set value can be modified through the program instruction. When Δw is 0,

no reserve will be left for machining on axis zX.

5) In program segment ns-nf, the size of axis X and Z must change in a single way (continuous increase or continuous decrease). Otherwise, the system will alarm

6) The program segment ns-nf can only include the following G instructions: G00, G01, G02, G03 and G04, but not the following M instructions: M00, M30, M98 and M99. Otherwise, the system will alarm.

7) Program segment Ns can only be G00 and G01. Otherwise, the system will alarm.

8) In MDI mode, instruction G72 can't be executed.

Example of programmed machining with G72

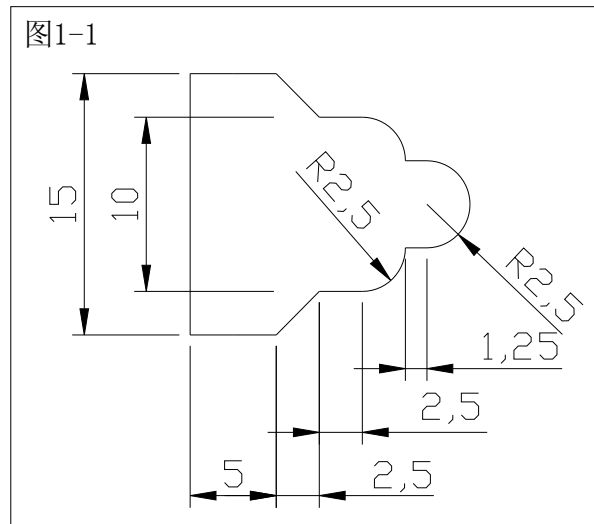

Fig. 3-11-6

```

O7201
M03S500T0101
G00X20Z5
M03S500F3000
G72W0.5R-0.4
G72Q20U0.2W0.2
N10G1X17Z-11.25F300
X15
W5
G1X10W2.5F200
G1W2.5F300
G02X5W2.5R2.5F200
G1W1.25F300
N20G2X0W2.5R2.5F200
G70P10Q20
G0X20
Z5

```

M30

%

3.6.3 Enclosed rough cutting cycle (G73)

Instruction format:

G73 U(Δi) W(Δk) R(d) F_ S_ T_
 G73 P(ns) Q(nf) U(Δu) W(Δw)

U(Δi): Reserve for rough machining on axis X, without symbol, ineffective with the minus "-" (radius);

W(Δk): Reserve for rough machining on axis Z, without symbol, ineffective with negative number.

R(d): Times of rough machining. Integer number without symbol, decimal fraction is ineffective (unit: times);

P(ns): Line number of start program segment for fine-machining locus;

Q(nf) : Line number of end program segment for fine-machining locus;

U(Δu): Reserve for fine-machining on axis X, without symbol, ineffective with the minus "-" (diameter);

W(Δw): Reserve for fine-machining on axis Z, without symbol, ineffective with the minus "-"

F: Feed speed in rough machining

S: Spindle speed in rough machining

T: Tool number, tool offset number

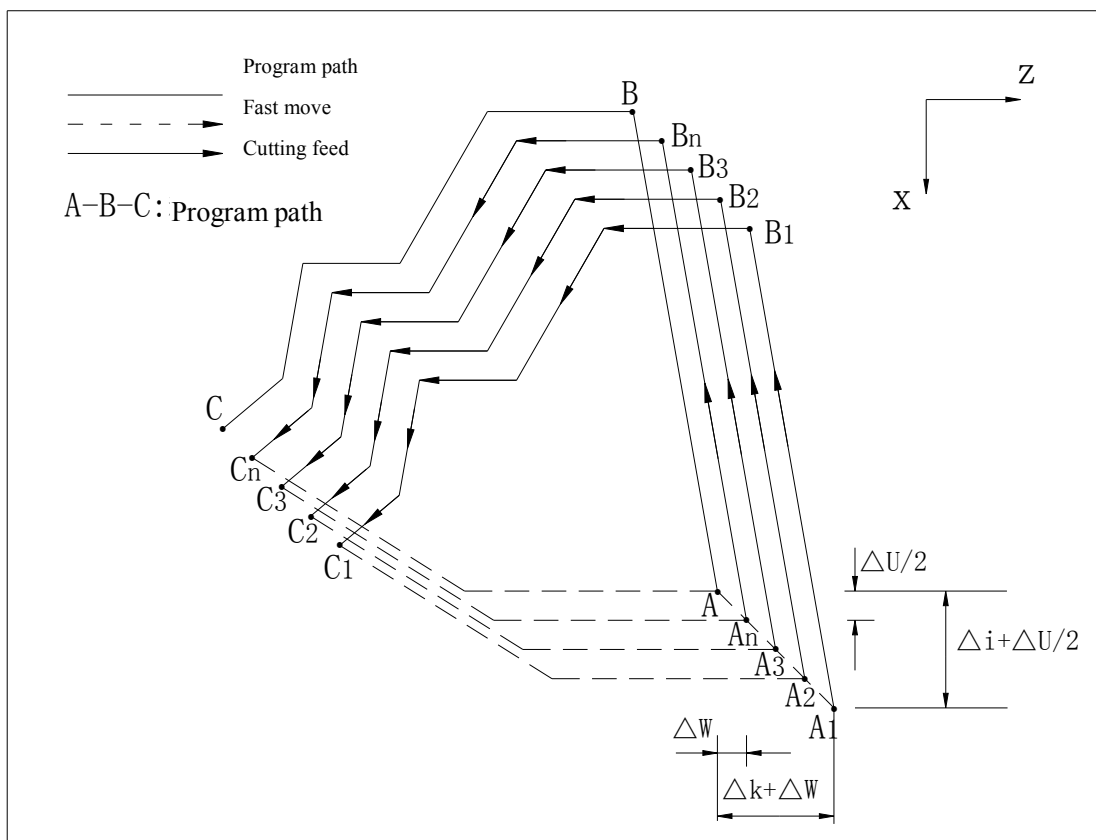

Execution process:

(1) A→A1: fast move;

(2) The first rough machining: A1→B1→C1→A2:

A1→B1→C1:B'→C': Interpolation mode is defined by program segment ns→nf.

The interpolation speed is subject to F value defined by G73 program segment. If not defined, the default F value will be used.

C1→A2: fast move

(3) The second rough machining, A2→B2→C2→A3:

A2→B2→C2: Interpolation mode is defined by program segment ns→nf.

The interpolation speed is subject to F value defined by G73 program segment. If not defined, the default F value will be used.

C2→A3: fast move

(4) The Nth rough machining cycle: An→Bn→Cn→A:

An→Bn→Cn: Interpolation mode is defined by program segment ns→nf. The interpolation speed is subject to F value defined by G73 program segment. If not defined, the default F value will be used.

Cn→A: fast move. Rough machining cycle ends.

- 1) Program segment must be compiled after G73 program segment. The system won't execute the program segment between G73 and ns→nf.
- 2) The F value in G73 program segment is effective when G73 rough machining cycle is executed. If F value is not defined in G73 program segment, the default F value will be used. The program segment ns-nf is effective only when G70 is executed.
- 3) In tool tip radius offset, if G73 is executed, the offset will be effective. However, in G73 cycle, the start point of the tool is the position where the tool tip radius offset is temporarily canceled.
- 4) At the time of execution in single-segment state, the system stops at the end point of each program segment. In movement, pause and resetting are effective
- 5) When a compound instruction is used for multiple times in the same program segment, it is not allowed that a program segment number be used repeatedly in ns~nf. Otherwise, the system may wrongly run ns~nf profile when the next compound instruction is executed.
- 6) Before the execution of G73, the start point of the tool must be defined. It must be at the outer side of the limit of the program path. Otherwise, the system will alarm. If the start point is not defined, the current point will be considered the start point.
- 7) To define the outer side of the program path, see the figure below.

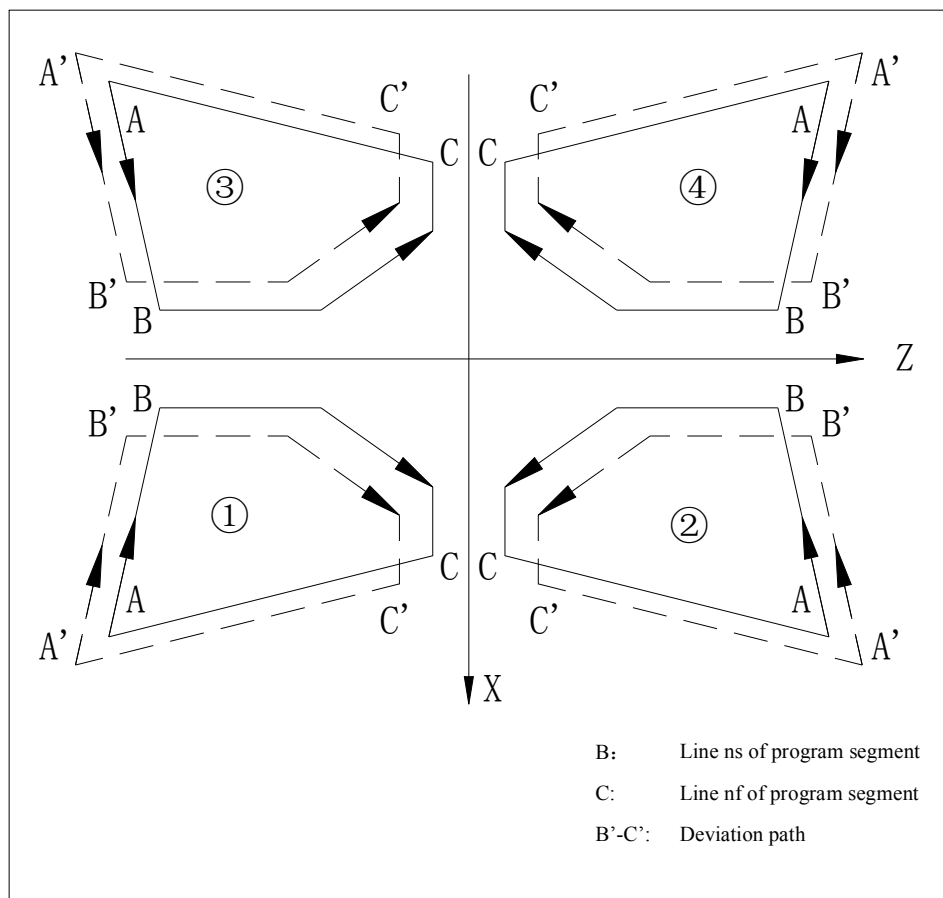

- 1) Δi can be set through the parameter (116-G73 allowance on axis X), and the set value can be modified through the program instruction. When Δi smaller than Δu , the system will alarm.
- 2) E can be set through the parameter (117-G73 allowance on axis Z for rough machining), and the set value can be modified through the program instruction. When Δk smaller than Δw , the system will alarm.
- 3) d can be set through the parameter (120-G73 cycle times), and the set value can be modified through the program instruction. When d is a non-integer greater than 1, the system will take the integer for calculation. When smaller than 1, consider it 1 for calculation.
- 4) When ns and nf are not defined, the system will alarm.
- 5) Δu can be set through the parameter (115-G72 allowance for fine machining on axis X), and the set value can be modified through the program instruction. When Δu w is 0, no reserve will be left for machining on axis zX.
- 6) Δu can be set through the parameter (119-G73 allowance for fine machining on axis Z), and the set value can be modified through the program instruction. When Δw w is 0, no reserve will be left for machining on axis zX.
- 7) In program segment ns-nf, the size of axis X and Z must change in a single way (continuous increase or continuous decrease). Otherwise, the system will alarm
- 8) The program segment ns-nf can only include the following G instructions: G00, G01, G02, G03 and G04, but not the following M instructions: M00, M30, M98 and

M99. Otherwise, the system will alarm.

9) Program segment Ns can only be G00 and G01. Otherwise, the system will alarm.

10) In MDI mode, instruction G73 can't be executed.

Example of programmed machining with G73

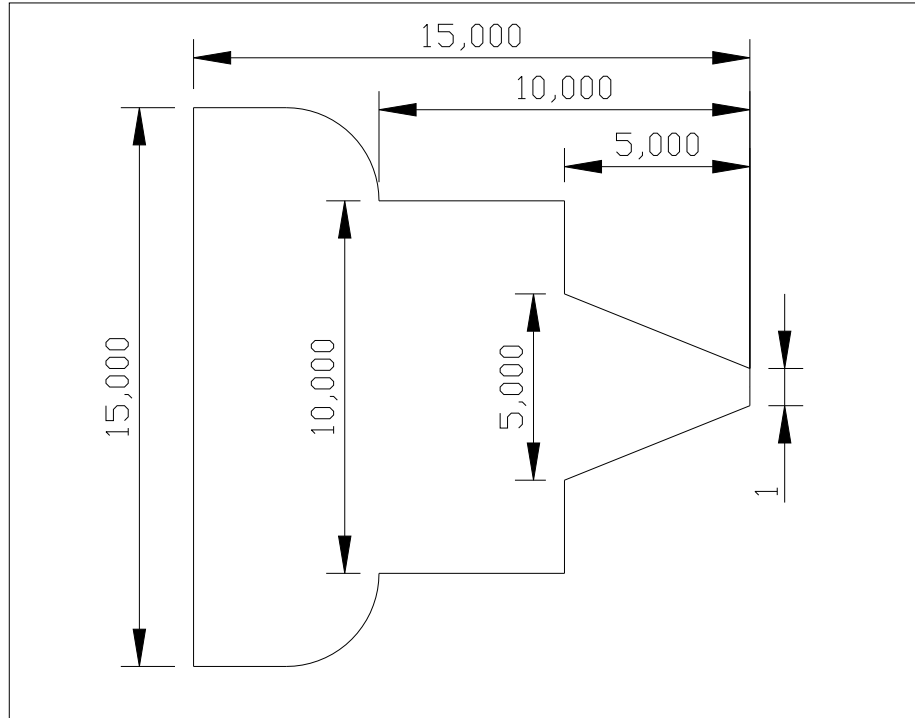

Fig. 3-11-8

```

O7301
M03S500T0101
G00X25Z5
G73U5W5R5F500
G73P10Q20U0.2W0.2
N10G0X1Z-0.5R0.5F300
X5Z-5
X10
Z-10
G03X15W-2.5R2.5
G1Z-15
N20G2X20W-2.5R2.5F200
G70P10Q20
G0X20
Z5
M30
%
```

3.6.4 Fine machining cycle (G70)

Instruction format: G70 P (ns) Q (nf);

P (ns): the number of the first program segment of the fine machining locus;

Q (nf): the number of the last program segment of the fine machining locus;

Definition: the knife performs fine machining along the ns~nf program segment from the start position. After the rough machining at G71, G72 or G73, perform the fine machining with G70 instruction, and finish the cutting of fine machining in one time. When G70 cycle completes, the knife returns to the start point and performs the next program segment after G70 program segment.

G70 instruction locus depends on the programming locus of the program segment between ns and nf. The relationship between the relative positions of ns and nf in G70~G73 program segment follows:

.

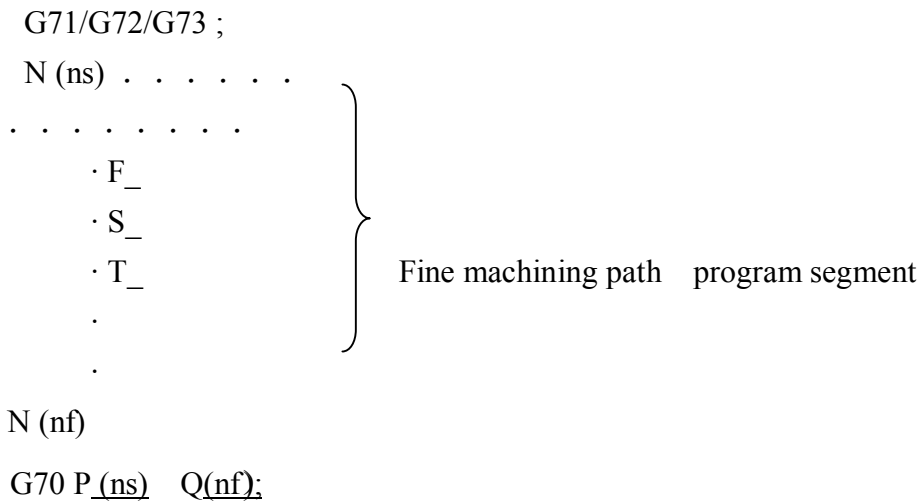

Description:

- When executing G70, the F, S and T instructions in program segment ns~nf

are available;

- When executing G70 instruction, it is possible to stop automatic running and move manually; however, to execute G70 cycle again, it is necessary to return to the position before manual movement. If not, the latter running locus will dislocate.
- In program segment ns~nf, the following instructions are unavailable:
 - Other G instructions except G04 (Pause) in group 00;
 - Other G instructions except G00, G01, G02 and G03 in group 01;
 - Sub-program transfer instruction (e.g. M98/M99)

3.6.5 Axial slot-cutting multi-cycle (G74)

Instruction format: G74 R(e);

G74 X/U _ Z/W_ P(Δ i) Q(Δ k) R(Δ d) F_;

R(e): Axial (axis Z) knife backward, no symbol

X/U: slot end point coordinates (X is the absolute coordinates and U is the increment from current coordinates to point coordinates)

Z/W: slot end point coordinates (Z is the absolute coordinates and W is the increment from current coordinates to point coordinates)

P(Δ i): single radial (axis X) offset of the knife, radius value, no symbol; the offset direction and the radial direction of the end point coordinates are same.

Q(Δ k): single axial (axis X) knife forward, no symbol; the knife forward direction and the axial direction of the end point coordinates are same.

R(Δ d): the radial (axis X) knife backwards after cutting to the slot bottom, no symbol; the knife backward direction and the radial offset direction are opposite.

F: feeding speed of axial slot cutting cycle

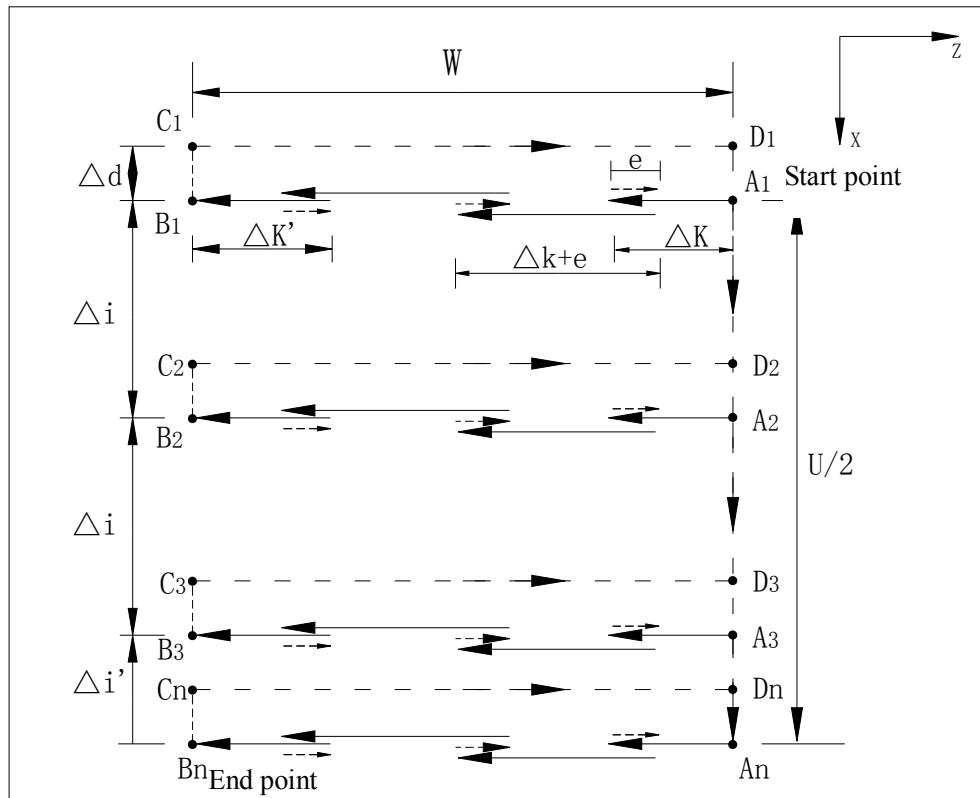

Process:

- ① First slot cutting cycle: $A_1 \rightarrow B_1 \rightarrow C_1 \rightarrow D_1 \rightarrow A_2$
 $A_1 \rightarrow B_1$: axial peck feeding to point B_1 ; $B_1 \rightarrow C_1 \rightarrow D_1 \rightarrow A_2$: quick movement (present cycle $B_1 \rightarrow C_1$ no knife backward action)
- ② Second slot cutting cycle: $A_2 \rightarrow B_2 \rightarrow C_2 \rightarrow D_2 \rightarrow A_3$
 $A_2 \rightarrow B_2$: axial peck feeding to point B_2 ; $B_2 \rightarrow C_2 \rightarrow D_2 \rightarrow A_3$: quick movement
- ③ The n^{th} slot cutting cycle: $A_n \rightarrow B_n \rightarrow C_n \rightarrow D_n \rightarrow A_1$
 $A_n \rightarrow B_n$: axial peck feeding to point B_n ; $B_n \rightarrow C_n \rightarrow D_n \rightarrow A_1$: quick movement. G74 slot cutting cycle completes

Function description:

- 1) Specify the position of cutting start point (A_1) before the slot cutting cycle, or else the system starts cutting from the current point.
- 2) In the first slot cutting cycle, when the knife cuts to the slot bottom (B_1), the knife doesn't retreat in radial direction
- 3) If the X/U isn't specified or the movement is 0, no matter whether $P(\Delta i)$ is specified, the system regards $P(\Delta i)$ as 0; in this case, only axis Z moves and cuts to slot end point, the knife doesn't retreat in radial direction
- 4) Peck feeding cycle

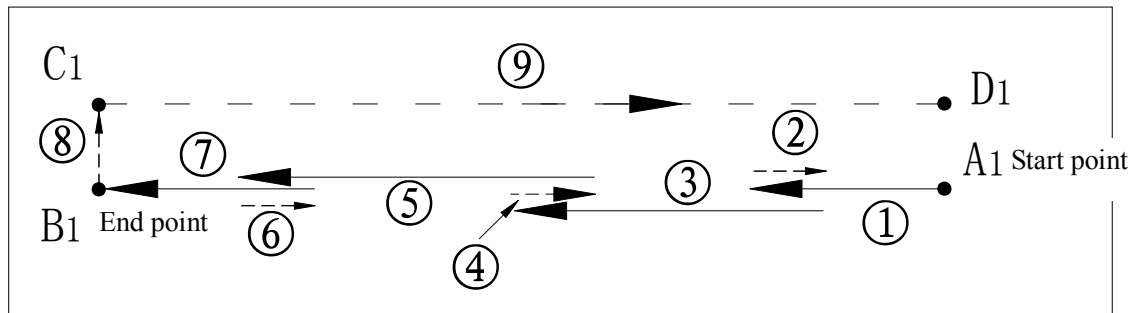

- 5) In single segment operation, the system stops in program segment $\textcircled{1}$ ~ $\textcircled{9}$; during the movement, press the Reset key or Pause key, and the system stops immediately.
- 6) Simple programming format: G74 X/U _ Z/W_F_; other omitted instruction addresses use the corresponding parameter values
- 7)

Related parameters and precautions:

- 1) e is set by parameter (100-G74 axial knife backward), or modified by program instruction; when e is 0, the system doesn't have axial knife backward action.
- 2) If the Z/W isn't specified or the movement is 0, the system alarms
- 3) Δi is set by parameter (101-G74 radial offset), or modified by program instruction; if X/U is specified, but P (Δi) is larger than the movement (U/2) of axis X, the system alarms. If P(Δi) is specified to 0, it can be used for axial cycle drilling
- 4) Δk is set by parameter (102-G74 axial knife forward), or modified by program instruction; if Δk is 0 or larger than slot depth (W), the system reports error.
- 5) Δd is set by parameter (103-G74 radial knife backward), or modified by program instruction; if Δd is 0, the knife doesn't retreat in radial direction; if Δd is larger than Δi , the system reports error.
- 6) In MDI mode, G74 instruction isn't available.

Example of machining with G74: see Fig. 3-11-10

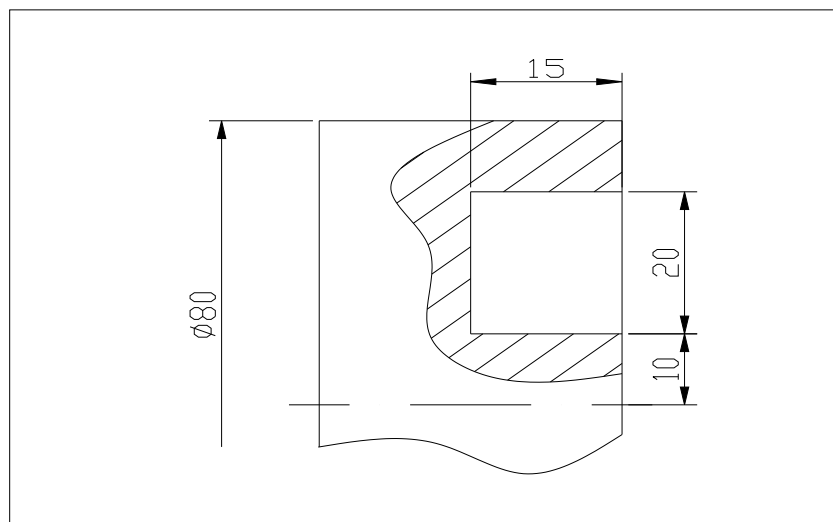

Fig. 3-11-10

```

O7401
G00X100Z20
M03S800T0101
G01X60Z2
G74R3
G74X20Z-15P2Q5R1F500
G00X100Z20
M30
%
```

3.6.6 Radial slot-cutting multi-cycle (G75)

Instruction format: G75 R_(e);

G75 X/U _ Z/W_ P (Δi) Q (Δk) R (Δd) F _ ;

R_(e): Radial (axis X) knife backward, no symbol

X/U: slot end point coordinates (X is the absolute coordinates and U is the increment from current coordinates to point coordinates)

Z/W: slot end point coordinates (Z is the absolute coordinates and W is the increment from current coordinates to point coordinates)

P(Δi): single radial knife forward, no symbol; the knife forward direction and the radial direction of the end point coordinates are same.

Q(Δk): radial offset of the knife, no symbol; the offset direction and the radial direction of the end point coordinates are same.

R (Δd): the radial (axis Z) knife backwards after cutting to the slot bottom, no symbol; the knife backward direction and the radial offset direction are opposite.

F: feeding speed of axial slot cutting cycle

11) Peck feeding cycle

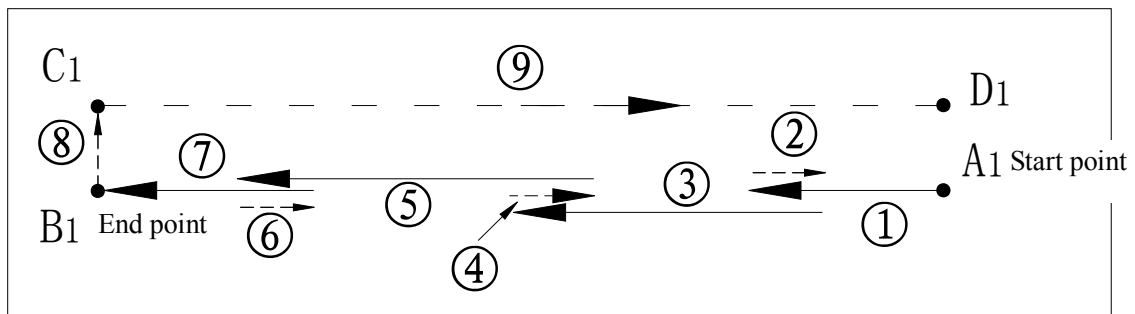

- 12) In single segment operation, the system stops in program segment Φ ~ Θ ; during the movement, press the Reset key or Pause key, and the system stops immediately.

Related parameters and precautions:

- 1) e is set by parameter (104-G75 radial knife backward), or modified by program instruction; when e is 0, the system doesn't have radial knife backward action.
- 2) If the X/U isn't specified or the movement is 0, the system alarms.
- 3) Δi is set by parameter (106-G75 radial knife forward), or modified by program instruction; if Δi is 0 or larger than the slot depth ($U/2$), the system alarms.
- 4) Δk is set by parameter (105-G75 axial offset), or modified by program instruction; if Z/W is specified, but larger than the movement (W) of axis Z, the system reports error. If Δk is specified to 0, it can be used for radial cycle drilling.
- 5) Δd is set by parameter (107-G75 axial knife backward), or modified by program instruction; if Δd is 0, the knife doesn't retreat in radial direction; if Δd is larger than Δk , the system reports error.
- 6) In MDI mode, G75 instruction isn't available.

Example of machining with G75: see Fig. 3-11-11

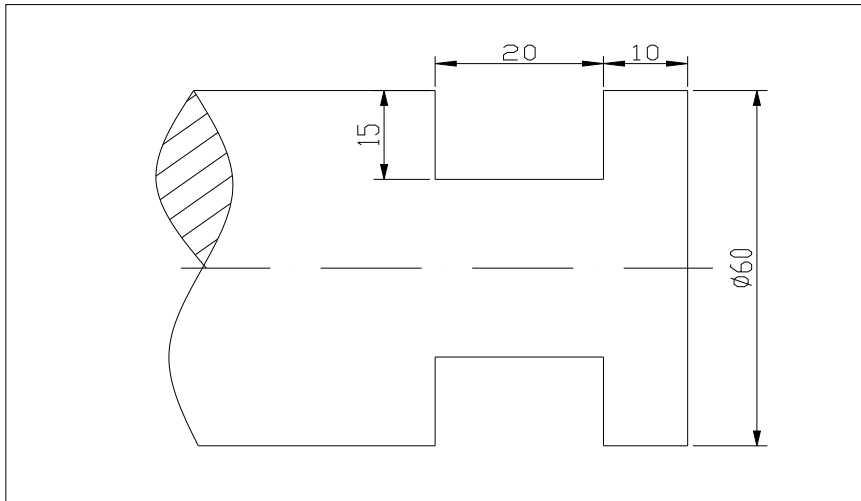

Fig. 3-11-12 G75 instruction cutting drawing

O7501

G00X100Z0

M03S800T0101

G01X80Z-10

G75R3

G75X30Z-30P5Q2R1F500

G00X100Z20

M30

1. CNC process

1. What is the main content of CNC programming?

Answer: CNC programming mainly includes: analyzing part drawing, determining the process and the process route, calculating the coordinates of knife locus, writing processing program, entering program to the CNC system, program verification and test cutting of first piece.

2. What are the objective and content of CNC process analysis?

Answer: To process parts on the CNC machine tool, first analyze and treat the process in accordance with part drawing, prepare CNC process technology, and then prepare

the processing program. The whole process is automatic. It includes the cutting amount of the machine tool, step arrangement, feeding line, process allowance, and tool dimensions and model.

3. What is knife alignment point? What is the influence of the selection of knife alignment point to programming?

Answer: The knife alignment point is the start point of the movement relative to the work piece during the CNC processing. This is also the start point of the program. The reasonable knife alignment point enables convenient mathematics treatment and simple programming; it is easy to correct on the machine tool, convenient for the checking during the processing and causes few processing error.

4. What are machine tool coordinates and work piece coordinates? And what are their differences?

Answer: The machine tool coordinates are also called as machine coordinates, which are the feeding movement coordinates of the machine tool parts. The axes and direction are regulated in accordance with the standard. The coordinate origin is set by the manufacturer, known as the machine origin (or parts). The work piece coordinates are also called as programming coordinates and used for programming.

5. Please introduce the knife point, knife replacing point and the work piece coordinate origin briefly.

Answer: The knife point is the reference point to determine the knife position. For the CNC machine tool with multiple-knife processing, it is necessary to set a knife replacing point during the processing. The knife replacing point is the reference point to convert the knife position. The determination of the knife replacing point position shall not produce interference. The origin of work piece coordinates is also known as the work piece origin or program origin. The position is set by the programmer at the design and process bases of the work piece generally, making the size calculation convenient.

6. What is the effect of knife compensation? What are the compensation instructions?

Answer: The knife compensation generally includes length compensation and radius compensation. The knife length compensation can compensate the length and position. With the knife radius compensation: perform rough and fine machining with the knife of same program and same size; program with part profile directly to avoid calculating knife-center path; if the diameter is changed due to knife wearing, heavy grinding and knife replacing, it is not necessary to modify the program, simply input the changed value of knife radius in knife parameter settings state; with the knife compensation function, it is possible to process the exterior and interior surfaces of same nominal size with the same program.

7. What is the separation between rough process and fine process? What is its advantage?

Answer: In determining the process of the components, please perform the rough and fine processing in stages, perform the fine processing after the rough processing of every surface; do not alternate the rough processing and fine processing, or perform both the rough processing and fine processing in the machine tool, which is called separation of rough processing and fine processing. This process enables rational use of machine tools, correcting the deformation and the error generated in rough processing in fine processing, and thus improving the processing precision. In addition, it is possible to detect the crack and spiracle earlier and stop the processing timely.

8. What are the advantages of clamping the work piece with fixture?

Answer: As the relative position between the positioning component of the fixture and the knife and the machine tool movement can be adjusted, so processing a number of

parts with fixture work piece does not require correcting one by one, but also ensures quick and easy operation, and high repeatability, as well as the processing requirements of the work piece.

9. What are the advantages of selecting fine benchmark in accordance with the principle of uniform benchmark?

Answer: The fine benchmark selected in this principle can be used to process multiple surfaces and multiple processes, reduce the error caused by benchmark change and improve the processing accuracy. In addition, it is possible to reduce the type of fixture and reduce the workload of designing fixtures.

10. What are the principles to determine the clamping direction?

Answer: (1) The direction of clamping action doesn't destroy the correctness of work piece orientation.

(2) The clamping direction shall make the clamping force as low as possible.

(3) The clamping direction shall make the work piece deformation as few as possible.

11. What are the factors of main axis rotation error?

Answer: Include the concentricity between the bearing bores of various bearings, the perpendicularity between shell hole position surface with the axis, the bearing clearance, the roundness of rolling bearing raceway and error of body shape, size, and the jiggling of locknut end surface, etc.

12. What are the negative consequences if the jiggling of the main axis shoulder bearing surface exceeds the tolerance?

Answer: If it exceeds the tolerance, the holes bored with main axis feeding and the datum plane deflect. In addition, if the toe fed with main axis doesn't wear evenly, and some knife edges wear and tear quickly, the cutter isn't economical.

13. How the materials difficult to process are measured?

Answer: The materials difficult to process are measured in the quality of processed surfaces, chip formation and the difficulty of discharging. As long as one of the above-mentioned three areas is significant poor, it can be taken as a material difficult to process.

14. What are the cutting characteristics of the materials difficult to process?

Answer: Shown in the following five areas:

- 1) Since the thermal conductivity of most materials difficult to process is low and the heat strength is high, the cutting temperature is high;
- 2) The chip deformation coefficient is large and the deformation hardening is severe;
- 3) The strength and thermal strength of the material are generally larger, and thus the cutting force is large;
- 4) The knife wears quickly, and thus the durability is low;
- 5) The rolling, breaking and disposal of chips are difficult.

15. What are the improvement measures of cutting materials difficult to process?

Answer: take the following improvement measures:

- 1) Select appropriate materials with good cutting performance;
- 2) Select a reasonable cutter geometry parameters;
- 3) Use a suitable cutting fluid;
- 4) Choose a reasonable amount of cutting.

16. What are the advantages of using index able hard alloy cutter?

Answer: Has the following advantages:

- 1) Since the blade isn't welded and the grinding isn't required, avoid the internal stress and cracks caused by welding grinding to increase knife life.

- 2) The knife can be used for a long time, and thus it will not only save the internal stress and cracks caused by welding grinding, but also increase the knife life.
 - 3) The knife can be used for a long time, and thus it will not only save materials, but also reduce the labor and equipment required by cutter manufacturing and grinding.
 - 4) If the knife is blunt, simply turn the blade position and continue to use, thus reduce the time of knife replacing and alignment.
 - 5) It is convenient to recover the blunt knives and thus the material consumption and costs are reduced.
17. What is the size basis?
Answer: The start size of the labeled size is the basis.
18. How to choose the basis during drawing?
Answer: The design basis shall be unified to the process basis and measuring basis. This can reduce processing errors, facilitate the measurement and testing.
19. What is the metal cutting process?
Answer: During the cutting, the tool edge cutting and the pushing of the knife surface make the cut metal slide and is cut to chips.
20. What is the effect of cutting amount to cutting force?
Answer: (1) When the cutting depth a_p and the feeding rate f increase, the cutting force increases, according to empirical formula for calculating cutting force $F_Z = 150a_p f^{0.75}$, we can know that the cutting depth increases by one time, and the main cutting force F_Z is doubled; the feeding amount is doubled, and the main cutting force F_Z is increased by 70% (due to increased feeding rate led to chip thickness increased, the chip deformation is reduced, so the cutting force is smaller).
(2) When cutting plastic metal, the cutting force is generally reduced with the increase in cutting speed; cutting brittle metals, the cutting speed does not show an impact on cutting force.
21. What are the materials in tool cutting part?
Answer: The materials currently used to manufacture knives include metal materials and non-metallic materials: metal materials include carbon tool steel, alloy tool steel, and high-speed hard alloy; non-metallic materials include synthetic diamond, cubic boron nitride and ceramics, in which carbon tool steel and alloy tool steel have poor red-performance (about 200~400°C), and very few is used to make knives.
22. What is the effect of cutting amount to cutting temperature?
Answer: the cutting speed is doubled, the cutting temperature is increased by 30% -40%; the feeding rate increased to double and the cutting temperature is increased by only 15%~20%; the cutting depth is increased to double and the cutting temperature is increased by only 5% -8%.
23. What is the process dimension chain?
Answer: The interrelated dimensions are arranged to a size closure map in a certain order of end to end, and it is called a dimension chain; the dimension chain applied in the processing is known as the process dimension chain.
24. What is the positioning error?
Answer: The position error of processing surface relative to the process basis caused by the work piece positioning is called as positioning error.
25. What are the eight aspects that may cause errors in processing?
Answer: Processing errors include principle error, clamping error, machine tool error,

fixture accuracy error, processing system deformation error, error in residual stress of the work piece, knife error and measurement error.

26. What is the objective of using fixtures in machinery manufacturing?

Answer: To ensure product quality, increase productivity, solve the special difficulties in machine tool processing, expand the processing range of machine tool, and reduce the technical requirements for workers

27. Which mandrels are used if the work piece is located with inner hole?

Answer: The commonly used mandrels are cylindrical mandrel, small taper spindle, cone mandrel, screw spindle, and splined spindle.

28. What are the roles of positioning devices and clamping devices?

Answer: The positioning device is used to determine the location of the work piece in the fixture, so that the work piece is at the correct location in the processing phase relative to the knives and cutting movement. The clamping device is used to clamp the work piece, ensure that the given position of the work piece in the fixture doesn't change in the processing.

29. What is the repeated positioning? What is part positioning?

Answer: The redundant number of degrees of freedom of the positioning point that should be limited, indicating that some positioning points limit the same degree of freedom repeatedly, and such positioning is called as repeated positioning.

30. What are machine tool errors and the major impact on the quality of processed parts?

Answer: The machine tool errors include:

- 1) The error between machine tool main axis and the bearing caused by manufacture and wearing. It has adverse effects to the roundness, flatness and the surface roughness of the parts;
- 2) The error is caused by machine tool wearing, and it causes error in the cylinder straightness;
- 3) Machine tool transmission error: it undermines the proper relationship between the movement and causes poor pitch;
- 4) The machine tool installation position error, such as the parallel error between guide rail and main axis installation, causes taper errors in processing the cylinder.

31. What is the geometric accuracy and working accuracy of the machine tool?

Answer: The geometric accuracy of machine tools is the geometric shape accuracy of some basic parts of the machine tool, the geometric accuracy of the relative position, and the geometric accuracy of the relative motion. The working accuracy of machine tool is the accuracy of the machine tool in motion state and under the action of cutting force. The accuracy of the machine tool in working state is reflected in the accuracy of the processed parts.

32. What are the conditions of ribbon cutting?

Answer: When processing plastic metal materials, the cutting speed is high, the cutting thickness is thin, and the anterior horn of the knife is large, due to the slide amount of the chip is smaller, but hasn't damaged the material, so the ribbon cutting is formed.

33. What is the significance of process analysis?

Answer: The correct process analysis has significant meaning in ensuring the processing quality, improving labor productivity, lowering production costs, reducing labor intensity and formulating a reasonable technical rules.

34. What are design basis and process basis (including assembly basis, positioning

basis, measurement basis and process basis)?

Answer: (1) Design basis refers to the basis to determine other points, lines, surfaces location on the parts drawing.

(2) Process basis refers to the basis used by the components in the processing and assembly process. According to their different purposes, it is divided into assembly basis, measurement basis, positioning basis and processes basis.

- 1) The assembly basis refers to the basis to determine the location of components in parts and products
- 2) The measurement basis is used to measure the size and location of the machined surface.
- 3) The positioning basis is used to make the work piece occupy the exact location in the machine tool or fixtures during processing.
- 4) The process basis refers to the basis used to determine the size, shape and position accuracy of processed surface on the process drawing.

35. What is the reason of positioning error and how to calculate?

Answer: When the workpieces are processed in the fixture, the main reasons causing processing dimension errors include:

- 1) The maximum displacement of the same batch of work pieces in processing direction caused by the size and geometry error of the positioning basis, and the clearance between positioning basis and positioning components is known as the positioning basis displacement error, and is indicated in $\tilde{N}Y$.
- 2) The offset of same batch of work pieces size relative to the process basis caused by the deviation of process basis and positioning basis is known as the basis deviation error, and is indicated in $\tilde{N}B$.

The sum of these two types of error is the positioning error, which is calculated in formula $\tilde{N}D = \tilde{N}Y + \tilde{N}B$. The positioning basis displacement error and basis deviation error that cause positioning errors also include rings respectively in calculation. For example, in addition to the clearance in $\tilde{N}Y$, it is also necessary to consider that the position error of geometric shape and fixture locating components (perpendicularity and coincidence degree) also can affect the basis displacement.